

STAND ALONE WORKSTATION BRIDGE CRANES



Cost-effective Solutions
For Lifting and Moving Material

STAND ALONE WORKSTATION BRIDGE CRANES

SPANCO Lifting Solutions...

*Increase worker productivity,
ease work flow and provide cost
effective material handling—
this is what SPANCO lifting
solutions can do for you.*

*No matter the material handling
problem, SPANCO has a solution.*



TABLE OF CONTENTS

	page
Solving your material handling problems...	3
Quality Considerations	3
Determining Capacity, Width, Length, and Height	4
Easy Installation and Modular Design	5
Design Factors	6
System Options	7
Components	9
Overview for Specification Charts	11
Chart Diagrams	12
System Specifications	13
Dimensional Charts	
20' Support Centers	14
25' Support Centers	24
30' Support Centers	30

In addition to providing solutions, we provide quality. Quality construction to ensure long life and easy, ergonomic service. Whether you need crane coverage for an area with minimal building support or coverage for a small workstation, SPANCO can provide an answer with our full lines of gantry cranes, jib cranes, and SPANCO enclosed track

workstation bridge cranes.



SOLVING YOUR MATERIAL HANDLING PROBLEMS WITH STAND ALONE WORKSTATION BRIDGE CRANES

STAND ALONE WORKSTATION BRIDGE CRANES

SPANCO stand alone workstation bridge cranes provide ideal, cost effective material handling solutions...

If you rent your building: Stand alone systems do not become a permanent part of a structure once installed, allowing for relocation.

Your structural building support is inadequate for an overhead ceiling mounted crane: The only mounting requirement is a standard concrete building floor (in most cases).

A specific area needs coverage, however you don't want to tie up your existing overhead crane: Stand alone SPANCO workstation bridge crane systems can provide coverage for individual work areas.

- **Easy movement:** An operator could be pushing a 1000 lb. load, however the operator will experience the force of approximately 10 lb. to begin moving the load and 8 lb. to continue moving the load (100 to 1 ratio). Also a manual crane operates more quickly than a motorized crane.
- If the application requires moving heavier loads up to two tons or bridge travel over an inaccessible area, then a motorized system can be used efficiently. (See page 7)

QUALITY CONSIDERATIONS

- **Low profile steel track** allows for full utilization of ceiling space. SPANCO systems are three times easier to operate and control than patented track systems.
- **"V" shaped profile** prevents dirt accumulation inside tracks and maintains alignment of end trucks and trolley wheels, ensuring smooth movement.
- **Trussed steel track design** increases span with fewer runway supports, lessening work area interference.

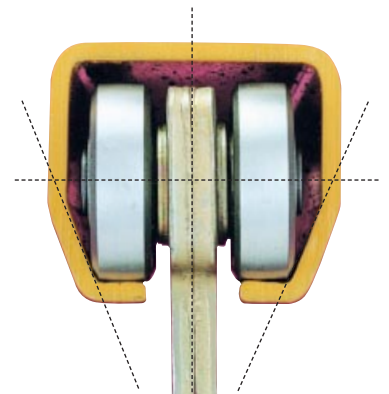

Machined steel wheels with crowned tread and zinc chromate corrosion resistant finish provide for absolute minimum rolling resistance and long operating life on end trucks and hoist trolleys.

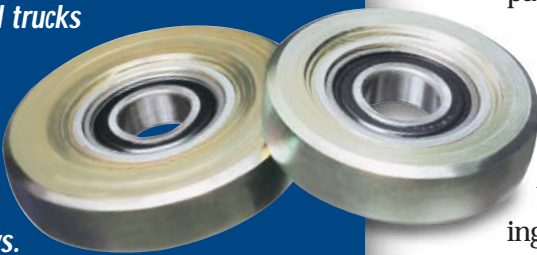

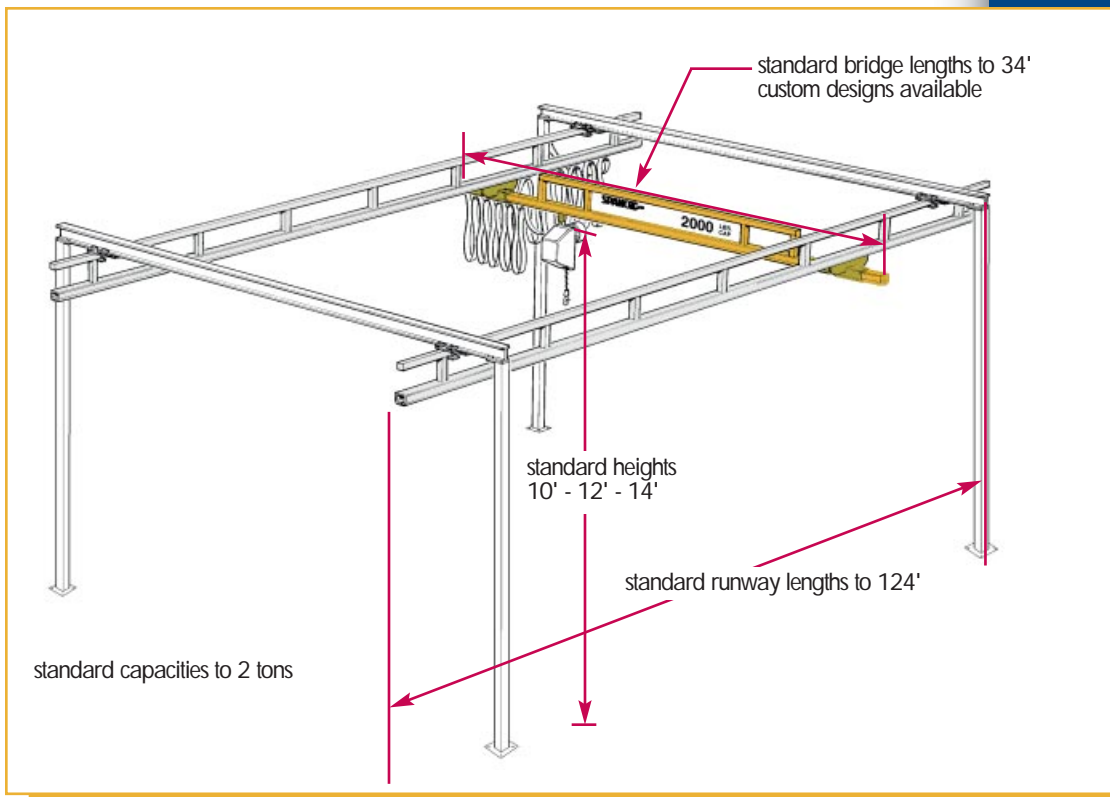

*Pre-engineered
system kit.
Everything supplied
except hoist and
anchor bolts.*

DETERMINING CAPACITY, WIDTH, LENGTH, AND HEIGHT

- **Capacity:** Load weights should be predetermined in order to avoid buying extra, unneeded capacity. Bridge dead weight will add more weight to the load the operator will be moving.
- **Width:** Bridge span is the length of a bridge between centers of two runways. SPANCO's standard design provides a standard bridge overhang of 12 in. on each end beyond the runway centerline. Bridge length is the overall length.
- **Length:** Runway length is determined by the length of a specific area requiring coverage. Runways are supported on maximum 20, 25, or 30 ft. support centers.
- **Height:** In order to attain minimal resistance, it is recommended that the trolley clevis height be kept as low as possible, with practical consideration given to minimum headroom requirements. Height is measured from the floor to the trolley clevis from which a hoist is suspended. The specification charts give the overall height of each system.



STAND ALONE WORKSTATION BRIDGE CRANES

SPANCO™ enclosed track workstations meet or exceed ANSI B30.11 standards for monorails and underhung cranes.

CHOICE OF PAINT FINISHES

All runways and structural supports are painted with SPANCO's Standard Grey enamel or optional "Ford Blue."

All bridges are painted SPANCO Yellow.



EASY INSTALLATION AND MODULAR DESIGN

- **Floor supported**, free standing systems are easily installed with the aid of a forklift.
- **Welded steel base plates** and gussets provide solid mounting connections between steel support columns and concrete floor.
- **Support columns** are designed to AISC specifications.
- **Pre-engineered modular design** allows for easy relocation and/or expansion by simply adding runway sections, freestanding support assemblies, and additional bridges.

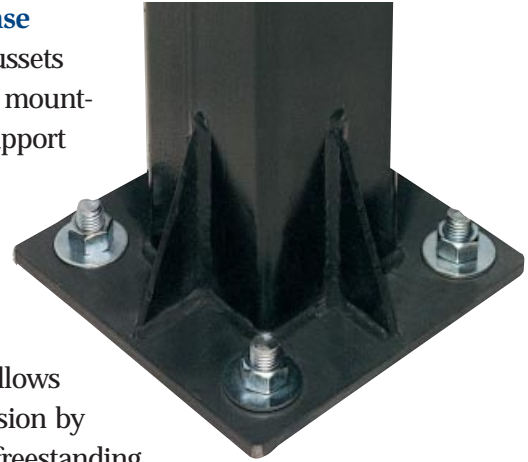

- **Splice joints** connect the track sections and are supplied complete with vertical and horizontal adjustment screws, facilitating precise alignment of the track sections.



- **Trussed splice joints** connect the top chord of the truss and link track sections for precise alignment.

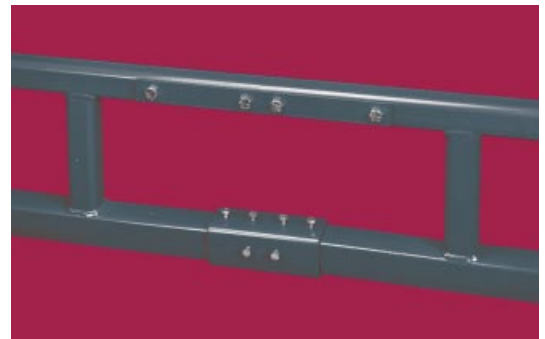

DESIGN FACTORS

- **Nameplate bridge capacity** represents the rated load on the hoist hook. The load rating of a hoist shall not exceed the bridge rating. SPANCO's design includes an allowance of 15% of nameplate capacity for dead weight of the trolley and hoist. An additional allowance of 25% of nameplate capacity is also included for impact.



SEISMIC DESIGN RATING

All SPANCO workstation bridge cranes meet design requirements for installation and use in seismic zone 4, of the uniform building code, the worst earthquake prone areas in North America

SERVICE FACTOR

All SPANCO workstation cranes are designed for frequent usage (*heavy service*) as defined:

- System or equipment is used where **operational time is up to 100% of the work period and lifted load is at 50% or below** rated capacity.
- System or equipment is used where **operational time is less than 50% of work period and lifted load is greater than 50%** of rated capacity.
- **Applications involving vacuums, magnets, or other high impact lifters** are considered severe usage (*continuous service*) and require special design considerations. Please contact factory for special design pricing.
- **CONSULT FACTORY FOR USAGE OTHER THAN MODERATE AND ALL INSTANCES OF HIGH CYCLE RATES OR HIGH IMPACT APPLICATIONS SUCH AS HIGH SPEED AIR OR ELECTRIC HOISTS, VACUUM LIFTERS, OR MAGNETS.**

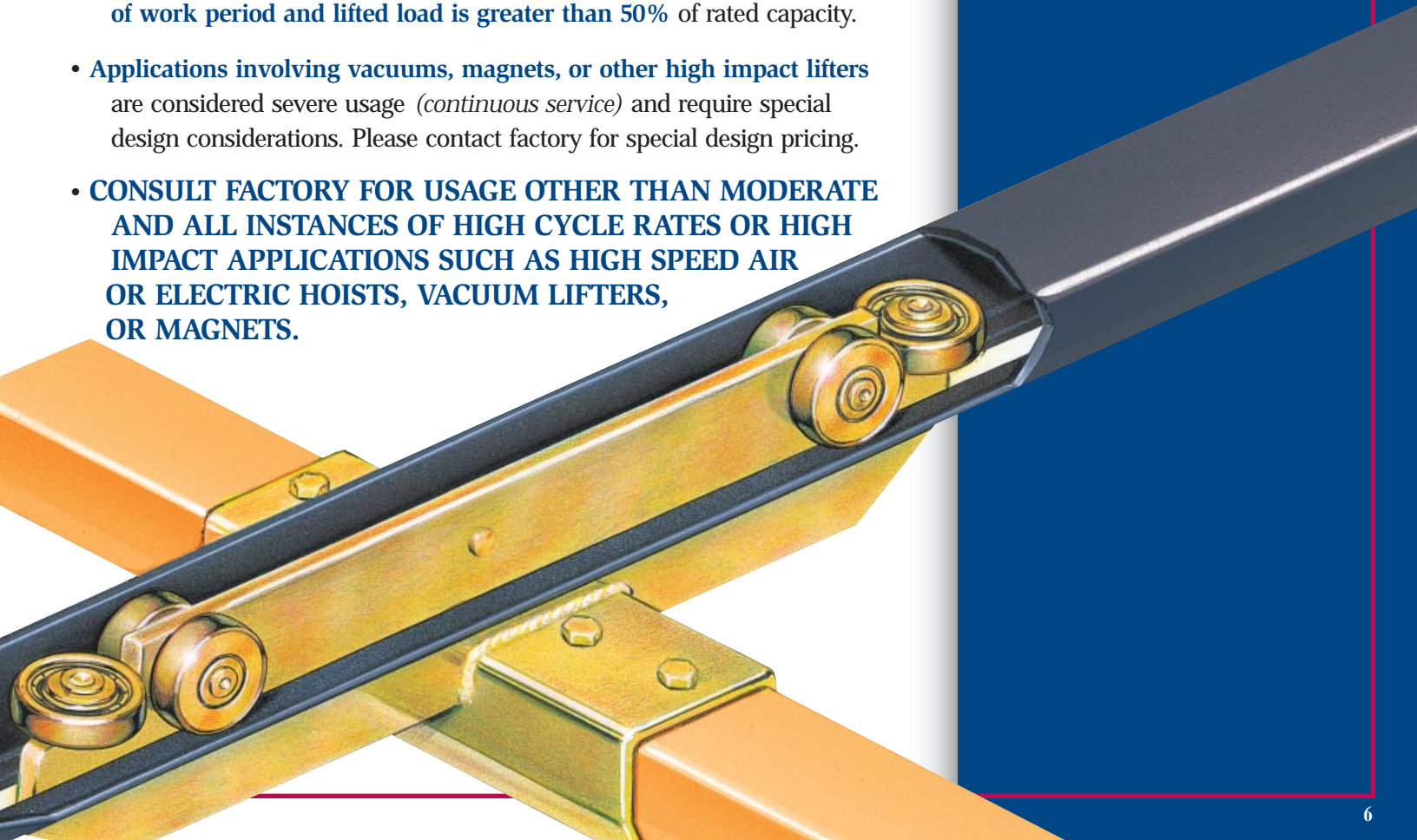

STAND ALONE WORKSTATION BRIDGE CRANES

SYSTEM OPTIONS

Mixed Capacity Systems

- Maximize system capability and efficiency by utilizing heavier capacity runways and smaller capacity, multiple bridges.



Bridge Buffer

- Example: Using a 2,000 lb. capacity runway system, two 1,000 lb. or four 500 lb. bridges can operate within the same runway support centers.

Bridge Buffers

- Roll in the runway tracks between two crane bridges restricting the distance they can travel towards each other, to avoid overloading runway.

Intermediate Crane End Stops

- Additional through-bolted end stops can be installed in the runway tracks at runway support centers to prevent more than one bridge crane from operating within a set of support centers.

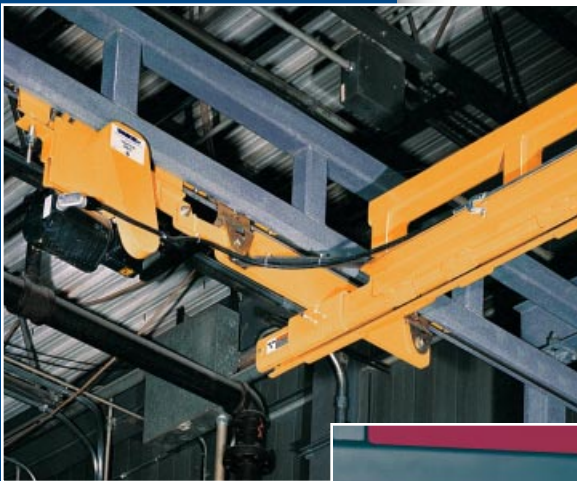

Tractor Drives

- Power bridge or trolley and hoist travel on straight 600, 700, or 900 series track (1000 to 4000 lb. capacities) runways or monorails.
- 208 to 575 volts, three phase, 60 hertz, electric operation, air driven also available.
- Standard speeds from 34 F.P.M. to 75 F.P.M. Other speeds available.



TELESCOPING
SYSTEM

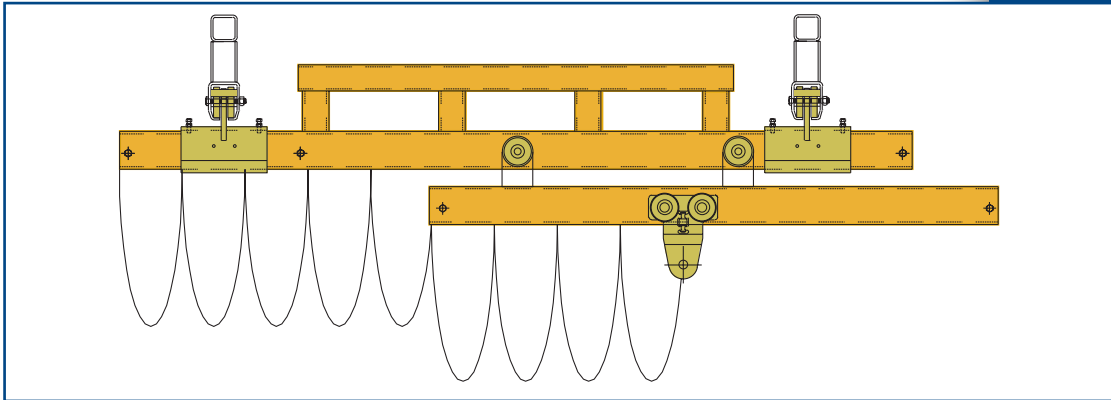

Telescoping Bridges

- Provide extended reach to areas beyond a column or under mezzanines or shelving; a neighboring workstation; or into a specific area or opening requiring coverage.
- Steel anti-kickup wheels prevent bridge binding, ensuring smooth movement.
- Range in capacities up to 2000 lb. For specific applications, consult factory for an engineered solution.

CANTILEVERED
SYSTEM

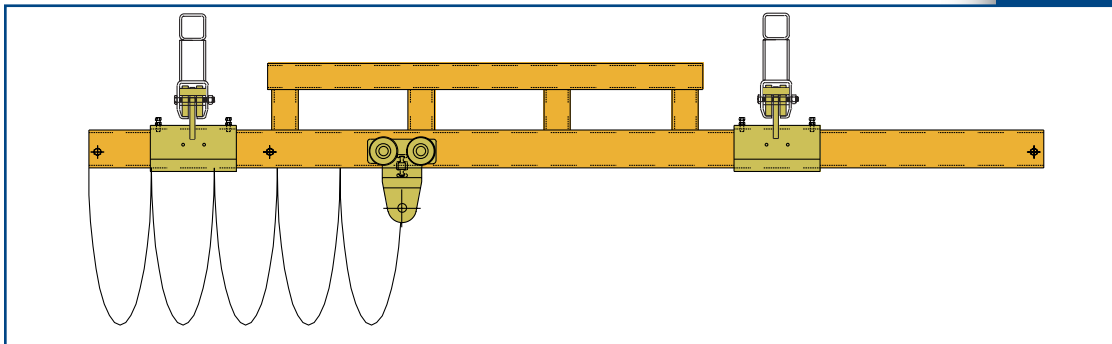

Cantilevered Bridges

- One or both ends of the crane bridge can be cantilevered beyond the standard 12 in. overhang in order to cover a wider area.
- For specific applications, consult factory for an engineered solution.

TRUSSED
CANTILEVERED
SYSTEM

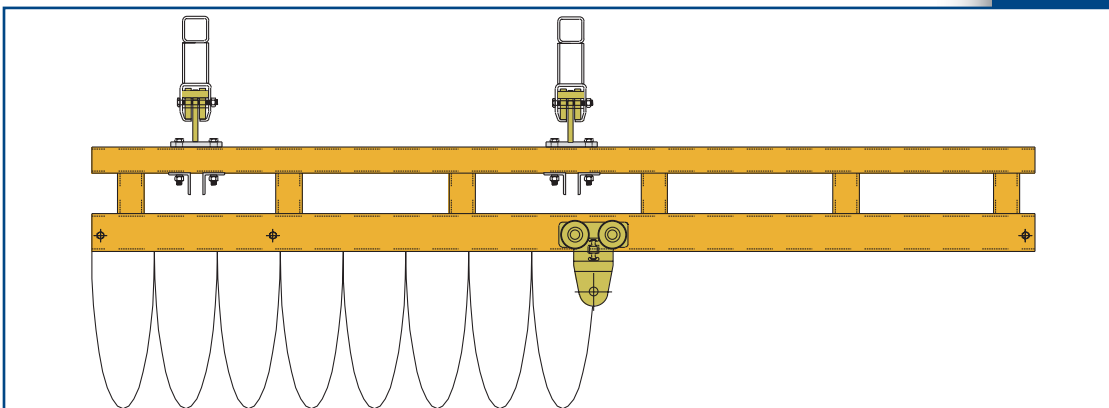

COMPONENTS WORKSTATION BRIDGE CRANES

1 END STOP BUMPER

- Through bolted to the track.
- Resilient rubber bumper increases impact resistance.
- Standard on all systems.



1 END STOP BUMPER

2 CABLE/HOSE TROLLEYS

- Utilized on powered hoist systems for conveying the power supply flat cable or round air hose from the static source to the powered hoist.
- Four wheels ensure smooth movement.
- Pivoting trolley clevis provides swiveling action for round air hose.
- Standard on all systems.



3 FESTOON SECTION

- Supplied to attach to the end of one runway to supply a stack-up section for the cable/hose trolleys.
- Allows complete end to end bridge travel.
- Standard on all systems.

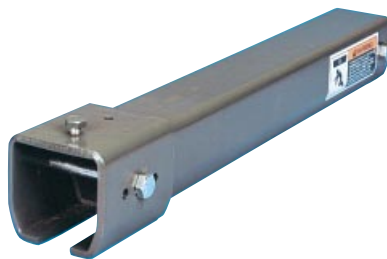

3 FESTOON SECTION

4 END TRUCK

- Provide smooth running connection between the bridge crane and runway track.
- Placement of horizontal steel wheels on either end of the end truck guards against "crabbing action" caused by non-parallel track profile, ensuring free movement.
- End trucks are designed to ANSI B30.11 specifications for underhung bridge cranes.

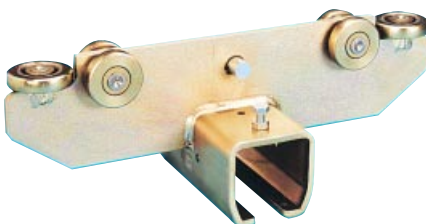

4 END TRUCK



5 HOIST TROLLEY

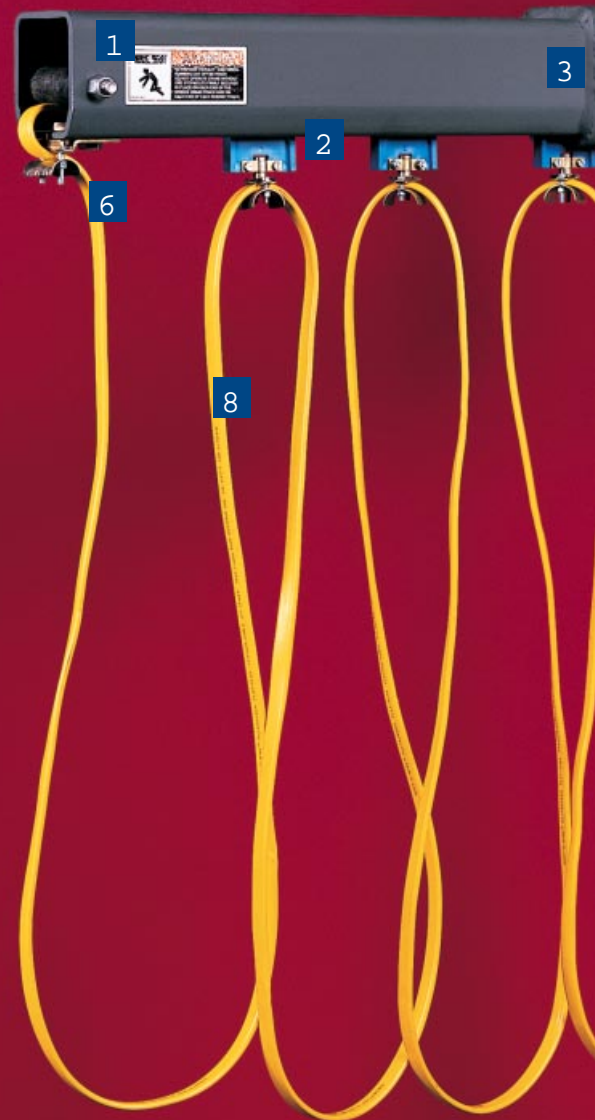

TR SERIES - FREE STANDING TRUSSED RUNWAY BRIDGE CRANE SYSTEMS

BL	RUNWAY LENGTH	BRIDGE & RUNWAY KIT NUMBER	TCH	SUPPORT KIT NUMBER	FESTOON DATA			DIMENSIONAL DATA							
					TROLLEY QTY	FTE	FCL	BRH	HEADER SIZE	HL	OAH	C/C	OAW	COL. SIZE	BASE DETAIL
23'	23'	TR-23-23-900	10'	S M 2 - 10 23	10	12"	58'	2'-7 1/8"	10"	25'-0"	13'-5 1/4"	23'-11"	25'-0"	7"	B
			12'	S M 2 - 12 23								15'-5 1/4"			
	33'	TR-23-33-900	10'	S M 3 - 10 23	12	24"	69'	2'-7 1/8"	10"	25'-0"	13'-5 1/4"	23'-11"	25'-0"	7"	B
			12'	S M 3 - 12 23								15'-5 1/4"			
	43'	TR-23-43-900	10'	S M 3 - 10 23	14	24"	79'	2'-7 1/8"	10"	25'-0"	13'-5 1/4"	23'-11"	25'-0"	7"	B
			12'	S M 3 - 12 23								15'-5 1/4"			
	53'	TR-23-53-900	10'	S M 4 - 10 23	15	36"	91'	2'-7 1/8"	10"	25'-0"	13'-5 1/4"	23'-11"	25'-0"	7"	B
			12'	S M 4 - 12 23								15'-5 1/4"			
63'	TR-23-63-900	10'	S M 4 - 10 23	17	36"	102'	2'-7 1/8"	10"	25'-0"	13'-5 1/4"	23'-11"	25'-0"	7"	B	
		12'	S M 4 - 12 23								15'-5 1/4"				
83'	TR-23-83-900	10'	S M 5 - 10 23	20	54"	124'	2'-7 1/8"	10"	25'-0"	13'-5 1/4"	23'-11"	25'-0"	7"	B	
		12'	S M 5 - 12 23								15'-5 1/4"				
103'	TR-23-103-900	10'	S M 6 - 10 23	24	54"	146'	2'-7 1/8"	10"	25'-0"	13'-5 1/4"	23'-11"	25'-0"	7"	B	
		12'	S M 6 - 12 23								15'-5 1/4"				
28'	23'	TR-28-23-900	10'	S U 2 - 10 28	11	12"	63'	2'-7 1/8"	14"	30'-0"	13'-9"	28'-11"	30'-0"	7"	B
			12'	S U 2 - 12 28								15'-9"			
	33'	TR-28-33-900	10'	S U 3 - 10 28	13	24"	74'	2'-7 1/8"	14"	30'-0"	13'-9"	28'-11"	30'-0"	7"	B
			12'	S U 3 - 12 28								15'-9"			
	43'	TR-28-43-900	10'	S U 3 - 10 28	15	24"	85'	2'-7 1/8"	14"	30'-0"	13'-9"	28'-11"	30'-0"	7"	B
			12'	S U 3 - 12 28								15'-9"			
	53'	TR-28-53-900	10'	S U 4 - 10 28	16	36"	96'	2'-7 1/8"	14"	30'-0"	13'-9"	28'-11"	30'-0"	7"	B
			12'	S U 4 - 12 28								15'-9"			
	63'	TR-28-63-900	10'	S U 4 - 10 28	18	36"	107'	2'-7 1/8"	14"	30'-0"	13'-9"	28'-11"	30'-0"	7"	B
			12'	S U 4 - 12 28								15'-9"			
	83'	TR-28-83-900	10'	S U 5 - 10 28	21	54"	129'	2'-7 1/8"	14"	30'-0"	13'-9"	28'-11"	30'-0"	7"	B
			12'	S U 5 - 12 28								15'-9"			
	103'	TR-28-103-900	10'	S U 6 - 10 28	25	54"	151'	2'-7 1/8"	14"	30'-0"	13'-9"	28'-11"	30'-0"	7"	B
			12'	S U 6 - 12 28								15'-9"			

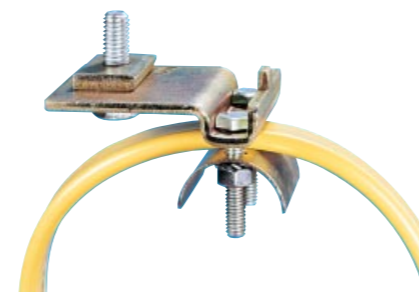
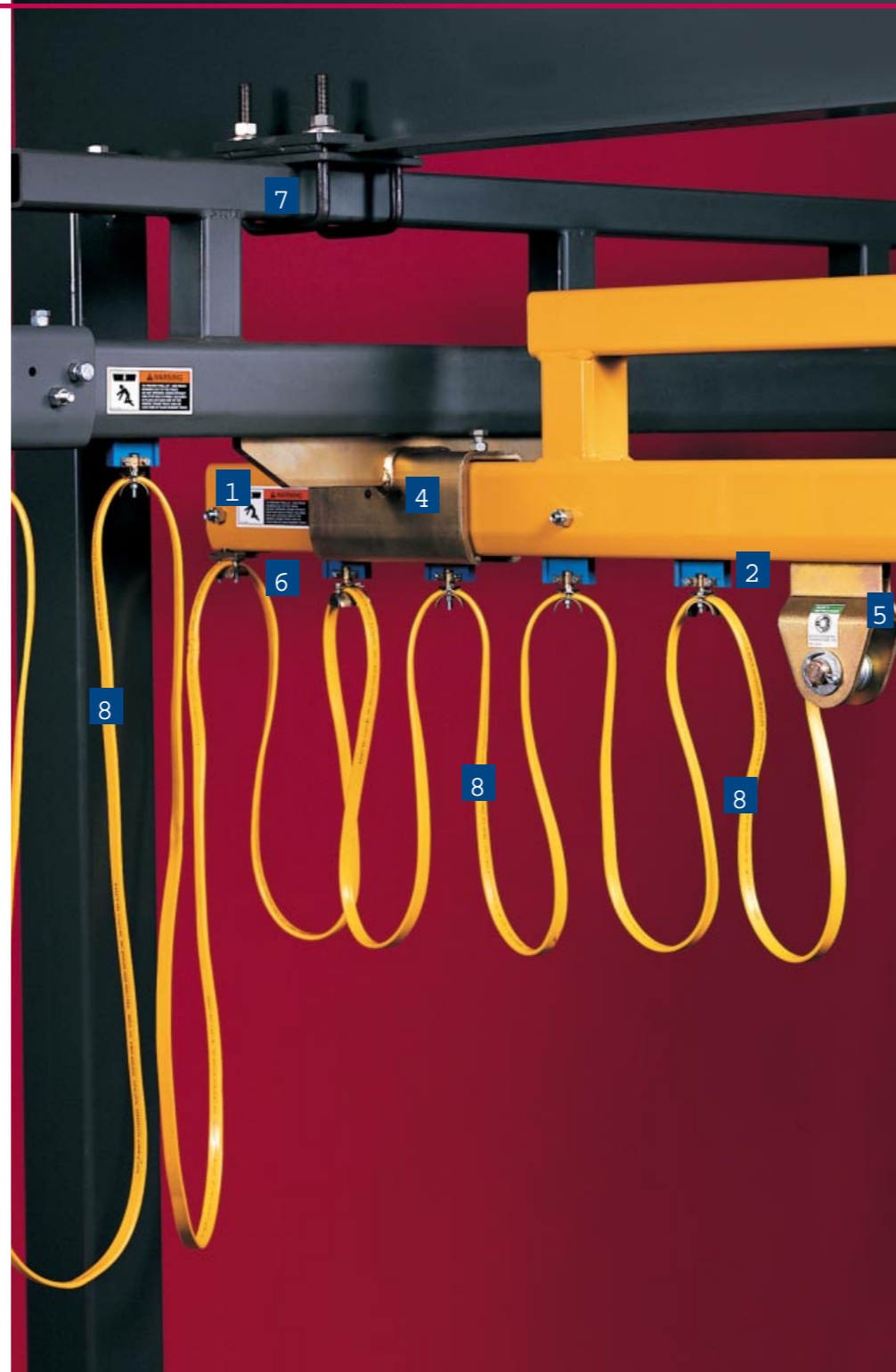

6 CABLE/HOSE CLAMP

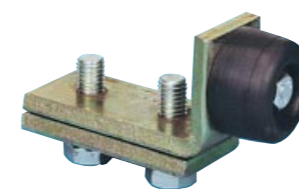

7 UNIVERSAL BUMPER (optional)

20' - 0" MAXIMUM SUPPORT CENTERS

4,000 LB. CAPACITY

23' - 28' BRIDGE LENGTH

20' - 0" MAXIMUM SUPPORT CENTERS

4,000

STAND ALONE WORKSTATION BRIDGE CRANES

SPECIFICATION CHARTS

SPANCO stand alone bridge crane dimensional charts are organized according to the length of the maximum support centers for each runway truss. Maximum runway support centers are 20, 25, and 30 feet. To help determine your specific runway support centers, consider the following points:

- The size of the building or specific area requiring coverage: Will the system cover the full building perimeter or a smaller specific area within a building?
- Location of fixed structures such as machinery, building columns, overhead lighting, and fixtures: These factors dictate support column placement and span between column support centers.
- Specific logistics of the area requiring coverage: Is the system moving material to an assembly line, into storage, or from one workstation to another?
- Specific headroom requirements: 20 ft. runway support centers allow for runway trusses with the shortest depth, maximizing headroom space under the hoist.

5 HOIST TROLLEY
 -Connection between lifting device and bridge.
 -Fabricated from precision cut steel plate.
 -Machined steel wheels ensure smooth movement.
 -Trolleys are designed to ANSI B30.11 specifications for underhung bridge cranes.

6 CABLE/HOSE CLAMPS
 -Fitted at one end of the runway and one end of the bridge.
 -Utilized where power feed is required.

7 HANGER ASSEMBLY
 -All stand alone systems are provided with flush type hanger assemblies which allow for adjustment in lateral and longitudinal directions. Hangers are of appropriate numbers and size for the selected system.

8 FLAT CABLE FESTOONING SYSTEMS (four wire)
 -Supplied with all systems.
 -Optional, various sized air hoses available.

UNIVERSAL BUMPER
 -Frictionally clamped to the track opening and must include a horizontal through bolt behind the bumper to protect it from being dislodged by impact.

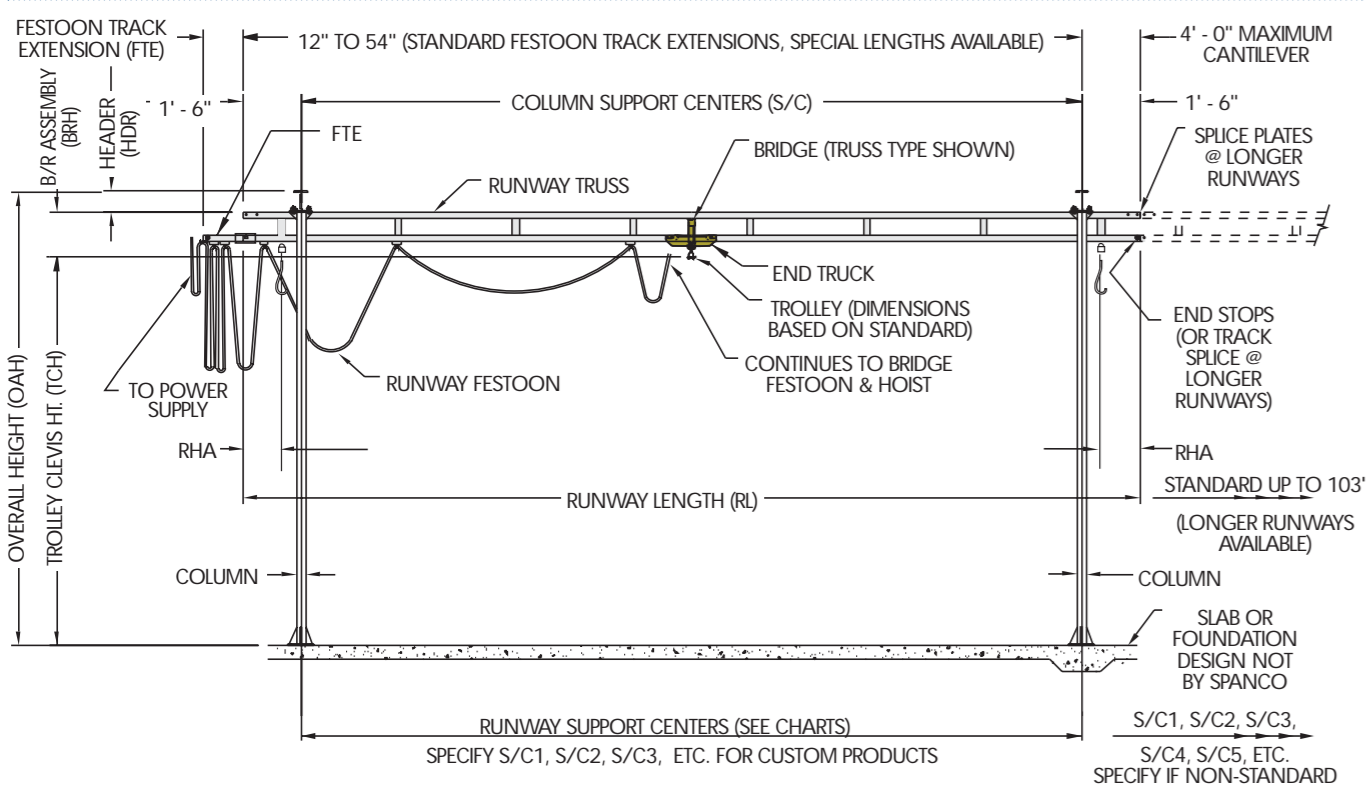
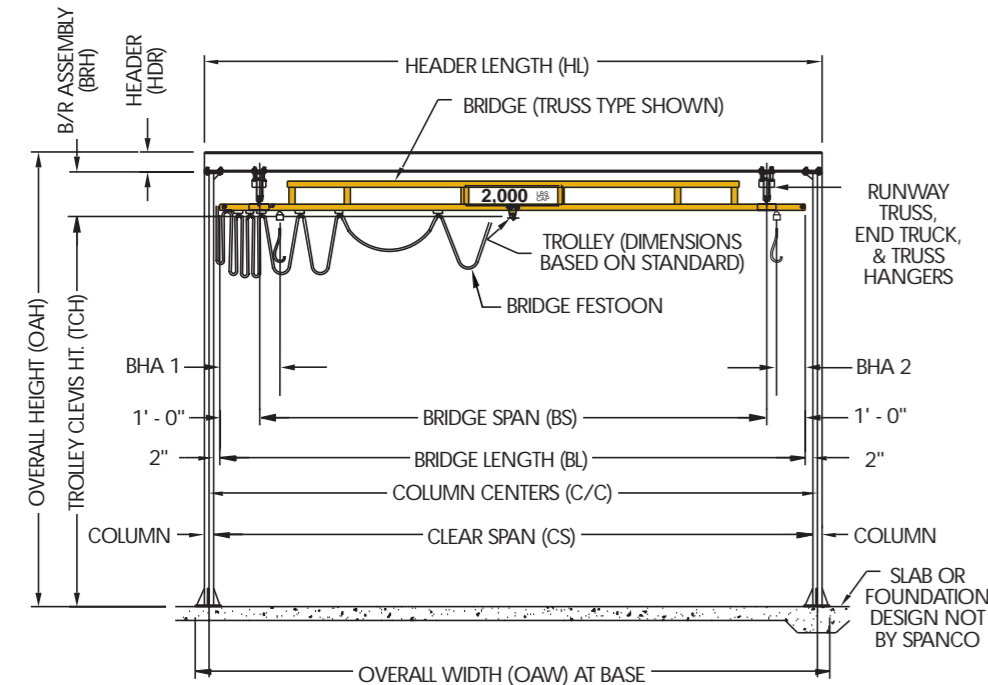

BRIDGE CRANE KITS & STAND ALONE KITS

CUSTOMER:	OVERALL RUNWAY LENGTH (RL):
TRACK SERIES:	CAPACITY:
NUMBER OF UNITS:	STANDARD SUPPORT CENTERS (S/C):
TROLLEY CLEVIS HT. (TCH):	RUNWAY SUPPORT CENTERS (S/C1):
BRIDGE / RUNWAY:	RUNWAY SUPPORT CENTERS (S/C2):
MODEL NUMBER:	RUNWAY SUPPORT CENTERS (S/C3):
RUNWAY SUPPORT ASSEMBLY:	RUNWAY SUPPORT CENTERS (S/C4):
MODEL NUMBER:	RUNWAY SUPPORT CENTERS (S/C5):
BRIDGE LENGTH (BL):	OVERALL HEIGHT (OAH):
CLEAR SPAN (CS):	ELECTRICAL REQMENTS:
OVERALL WIDTH (OAW):	FESTOON TRACK EXTENSION (FTE):
	FESTOON CABLE LENGTH (FCL):

END APPROACH

		HOOK APPROACH DATA																			
		300 SERIES			400 SERIES			500 SERIES			600 SERIES			700 SERIES			900 SERIES				
SYSTEM DATA	BL	BHA1	BHA2	RHA	BHA1	BHA2	RHA	BHA1	BHA2	RHA	BHA1	BHA2	RHA	BHA1	BHA2	RHA	BHA1	BHA2	RHA		
8'	8 1/8"	2 7/8"	8"	10 1/2"	3 1/4"	9 3/4"	18 5/8"	3 5/8"	10 5/16"	20"	4 1/8"	11 1/4"	22 1/8"	5 3/8"	13 7/16"	38 1/8"	21 3/8"	33 15/16"			
10'	10 3/4"	2 7/8"	8"	14"	3 1/4"	9 3/4"	18 5/8"	3 5/8"	10 5/16"	20"	4 1/8"	11 1/4"	22 1/8"	5 3/8"	13 7/16"	38 1/8"	21 3/8"	33 15/16"			
15'	13 3/8"	2 7/8"	8"	17 1/2"	3 1/4"	9 3/4"	18 5/8"	3 5/8"	10 5/16"	20"	4 1/8"	11 1/4"	22 1/8"	5 3/8"	13 7/16"	38 1/8"	21 3/8"	33 15/16"			
20'	18 5/8"	2 7/8"	8"	24 1/2"	3 1/4"	9 3/4"	25 1/2"	3 5/8"	10 5/16"	25 7/8"	4 1/8"	11 1/4"	27"	5 3/8"	13 7/16"	43"	21 3/8"	33 15/16"			
23'	N/A	N/A	N/A	28"	3 1/4"	9 3/4"	29"	3 5/8"	10 5/16"	29 3/8"	4 1/8"	11 1/4"	30 1/2"	5 3/8"	13 7/16"	46 1/2"	21 3/8"	33 15/16"			
28'	N/A	N/A	N/A	31 1/2"	3 1/4"	19 5/16"	32 1/2"	3 5/8"	19 7/8"	32 7/8"	4 1/8"	20 3/4"	34"	5 3/8"	29 3/16"	50"	21 3/8"	33 15/16"			
34'	N/A	N/A	N/A	N/A	N/A	N/A	43"	3 5/8"	19 7/8"	43 3/8"	4 1/8"	20 3/4"	44 1/2"	5 3/8"	29 3/16"	N/A	N/A	N/A			

Applies to all runway lengths up to 108'

COLUMN DETAILS

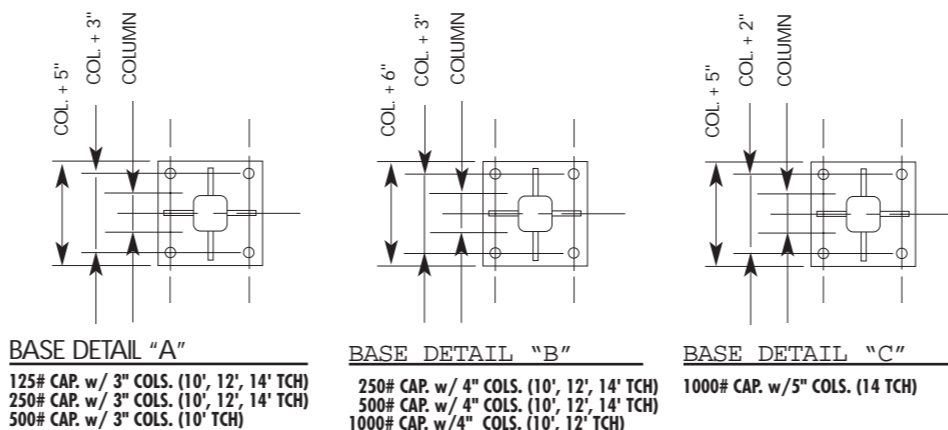

SYSTEM SPECIFICATIONS FOR STAND ALONE KITS

SPANCO Stand Alone Workstation Bridge Crane kits include:

1. Plain, reinforced, or trussed crane bridge with end trucks
2. Hoist trolley
3. Runway support columns
4. Runway trusses
5. Header beams
6. Hanger clamps, end stops, and flat wire electrification festooning system for both runway and bridge

SYSTEM REQUIREMENTS:

- Bracing to building steel for lateral and longitudinal stability required (furnished by others). To achieve desired rigidity for an application, SPANCO recommends consulting a professional engineer in your area to satisfy all codes and ordinances.
- Four 3/4" diameter anchor bolts required per column (furnished by others).
- Hoist supplied by others.

OTHER SYSTEM CONSIDERATIONS:

- Per SPANCO's design standard, deflection shall not exceed 1/450 of span. SPANCO can design to meet any higher customer standard.
- SPANCO Stand Alone Workstations are for frequent usage in a normal industrial environment.
- Maximum support spacing for trussed track at rated capacity shall not exceed:
 - 400 Series = 20' or 25'
 - 500 Series = 20', 25', or 30'
 - 600 Series = 20', 25', or 30'
 - 700 Series = 20', 25', or 30'
 - 900 Series = 20' or 25'

- Dimensions shown are approximate and are subject to change without notice. All catalog dimensions are developed using standard components for the spans and capacities required. Substitution of optional trolleys or other components will affect certain dimensions if specific clearances are required at the time of order.

TR SERIES - FREE STANDING TRUSSED RUNWAY BRIDGE CRANE SYSTEMS

BL	RUNWAY LENGTH	BRIDGE & RUNWAY KIT NUMBER	TCH	FESTOON DATA			DIMENSIONAL DATA								
				SUPPORT KIT NUMBER	TROLLEY QTY	FTE	FCL	BRH	HEADER SIZE	HL	OAH	C/C	OAW	COL SIZE	BASE DETAIL
10'	11.5'	TR-10-11.5-900	10'	S K 2-10 10	5	12"	30'	2'-7 1/8"	8"	11'-7"	13'-3 1/8"	10'-11"	12'-0"	7"	B
			12'	S K 2-12 10							15'-3 1/8"				
	23'	TR-10-23-900	10'	S K 2-10 10	6	12"	43'	2'-7 1/8"	8"	11'-7"	13'-3 1/8"	10'-11"	12'-0"	7"	B
			12'	S K 2-12 10							15'-3 1/8"				
	33'	TR-10-33-900	10'	S K 3-10 10	8	24"	54'	2'-7 1/8"	8"	11'-7"	13'-3 1/8"	10'-11"	12'-0"	7"	B
			12'	S K 3-12 10							15'-3 1/8"				
	43'	TR-10-43-900	10'	S K 3-10 10	10	24"	64'	2'-7 1/8"	8"	11'-7"	13'-3 1/8"	10'-11"	12'-0"	7"	B
			12'	S K 3-12 10							15'-3 1/8"				
	53'	TR-10-53-900	10'	S K 4-10 10	11	36"	76'	2'-7 1/8"	8"	11'-7"	13'-3 1/8"	10'-11"	12'-0"	7"	B
			12'	S K 4-12 10							15'-3 1/8"				
63'	TR-10-63-900	10'	S K 4-10 10	13	36"	87'	2'-7 1/8"	8"	11'-7"	13'-3 1/8"	10'-11"	12'-0"	7"	B	
		12'	S K 4-12 10							15'-3 1/8"					
83'	TR-10-83-900	10'	S K 5-10 10	16	54"	109'	2'-7 1/8"	8"	11'-7"	13'-3 1/8"	10'-11"	12'-0"	7"	B	
		12'	S K 5-12 10							15'-3 1/8"					
103'	TR-10-103-900	10'	S K 6-10 10	20	54"	131'	2'-7 1/8"	8"	11'-7"	13'-3 1/8"	10'-11"	12'-0"	7"	B	
		12'	S K 6-12 10							15'-3 1/8"					
15'	23'	TR-15-23-900	10'	S L 2-10 15	7	12"	49'	2'-7 1/8"	10"	17'-0"	13'-5 3/8"	15'-11"	17'-0"	7"	B
			12'	S L 2-12 15							15'-5 3/8"				
	33'	TR-15-33-900	10'	S L 3-10 15	9	24"	60'	2'-7 1/8"	10"	17'-0"	13'-5 3/8"	15'-11"	17'-0"	7"	B
			12'	S L 3-12 15							15'-5 3/8"				
	43'	TR-15-43-900	10'	S L 3-10 15	11	24"	70'	2'-7 1/8"	10"	17'-0"	13'-5 3/8"	15'-11"	17'-0"	7"	B
			12'	S L 3-12 15							15'-5 3/8"				
	53'	TR-15-53-900	10'	S L 4-10 15	12	36"	82'	2'-7 1/8"	10"	17'-0"	13'-5 3/8"	15'-11"	17'-0"	7"	B
			12'	S L 4-12 15							15'-5 3/8"				
	63'	TR-15-63-900	10'	S L 4-10 15	14	36"	93'	2'-7 1/8"	10"	17'-0"	13'-5 3/8"	15'-11"	17'-0"	7"	B
			12'	S L 4-12 15							15'-5 3/8"				
83'	TR-15-83-900	10'	S L 5-10 15	17	54"	115'	2'-7 1/8"	10"	17'-0"	13'-5 3/8"	15'-11"	17'-0"	7"	B	
		12'	S L 5-12 15							15'-5 3/8"					
103'	TR-15-103-900	10'	S L 6-10 15	21	54"	137'	2'-7 1/8"	10"	17'-0"	13'-5 3/8"	15'-11"	17'-0"	7"	B	
		12'	S L 6-12 15							15'-5 3/8"					
20'	23'	TR-20-23-900	10'	S L 2-10 20	9	12"	54'	2'-7 1/8"	10"	22'-0"	13'-5 3/8"	20'-11"	22'-0"	7"	B
			12'	S L 2-12 20							15'-5 3/8"				
	33'	TR-20-33-900	10'	S L 3-10 20	11	24"	65'	2'-7 1/8"	10"	22'-0"	13'-5 3/8"	20'-11"	22'-0"	7"	B
			12'	S L 3-12 20							15'-5 3/8"				
	43'	TR-20-43-900	10'	S L 3-10 20	13	24"	75'	2'-7 1/8"	10"	22'-0"	13'-5 3/8"	20'-11"	22'-0"	7"	B
			12'	S L 3-12 20							15'-5 3/8"				
	53'	TR-20-53-900	10'	S L 4-10 20	14	36"	87'	2'-7 1/8"	10"	22'-0"	13'-5 3/8"	20'-11"	22'-0"	7"	B
			12'	S L 4-12 20							15'-5 3/8"				
	63'	TR-20-63-900	10'	S L 4-10 20	16	36"	98'	2'-7 1/8"	10"	22'-0"	13'-5 3/8"	20'-11"	22'-0"	7"	B
			12'	S L 4-12 20							15'-5 3/8"				
83'	TR-20-83-900	10'	S L 5-10 20	19	54"	120'	2'-7 1/8"	10"	22'-0"	13'-5 3/8"	20'-11"	22'-0"	7"	B	
		12'	S L 5-12 20							15'-5 3/8"					
103'	TR-20-103-900	10'	S L 6-10 20	23	54"	142'	2'-7 1/8"	10"	22'-0"	13'-5 3/8"	20'-11"	22'-0"	7"	B	
		12'	S L 6-12 20							15'-5 3/8"					



BRIDGE CRANE KITS & STAND ALONE KITS

TR SERIES - FREE STANDING TRUSSED RUNWAY BRIDGE CRANE SYSTEMS

BL	RUNWAY LENGTH	BRIDGE & RUNWAY KIT NUMBER	FESTOON DATA				DIMENSIONAL DATA								
			TCH	SUPPORT KIT NUMBER	TROLLEY QTY	FTE	FCL	BRH	HEADER SIZE	HL	OAH	C/C	OAW	COL. SIZE	BASE DETAIL
10'	11.5'	TR - 10 - 11.5 - 400	10' 12' 14'	S A 2 - 10 10 S A 2 - 12 10 S A 2 - 14 10	5	12"	30'	1'- 2"	6"	10'-10"	11'-8" 13'-8" 15'-8"	10'-7"	11'-3"	3"	A
	23'	TR - 10 - 23 - 400	10' 12' 14'	S A 2 - 10 10 S A 2 - 12 10 S A 2 - 14 10	6	12"	43'	1'- 2"	6"	10'-10"	11'-8" 13'-8" 15'-8"	10'-7"	11'-3"	3"	A
	33'	TR - 10 - 33 - 400	10' 12' 14'	S A 3 - 10 10 S A 3 - 12 10 S A 3 - 14 10	8	24"	54'	1'- 2"	6"	10'-10"	11'-8" 13'-8" 15'-8"	10'-7"	11'-3"	3"	A
	43'	TR - 10 - 43 - 400	10' 12' 14'	S A 3 - 10 10 S A 3 - 12 10 S A 3 - 14 10	10	24"	64'	1'- 2"	6"	10'-10"	11'-8" 13'-8" 15'-8"	10'-7"	11'-3"	3"	A
	53'	TR - 10 - 53 - 400	10' 12' 14'	S A 4 - 10 10 S A 4 - 12 10 S A 4 - 14 10	11	36"	76'	1'- 2"	6"	10'-10"	11'-8" 13'-8" 15'-8"	10'-7"	11'-3"	3"	A
	63'	TR - 10 - 63 - 400	10' 12' 14'	S A 4 - 10 10 S A 4 - 12 10 S A 4 - 14 10	13	36"	87'	1'- 2"	6"	10'-10"	11'-8" 13'-8" 15'-8"	10'-7"	11'-3"	3"	A
	83'	TR - 10 - 83 - 400	10' 12' 14'	S A 5 - 10 10 S A 5 - 12 10 S A 5 - 14 10	16	54"	109'	1'- 2"	6"	10'-10"	11'-8" 13'-8" 15'-8"	10'-7"	11'-3"	3"	A
	103'	TR - 10 - 103 - 400	10' 12' 14'	S A 6 - 10 10 S A 6 - 12 10 S A 6 - 14 10	20	54"	131'	1'- 2"	6"	10'-10"	11'-8" 13'-8" 15'-8"	10'-7"	11'-3"	3"	A
15'	23'	TR - 15 - 23 - 400	10' 12' 14'	S A 2 - 10 15 S A 2 - 12 15 S A 2 - 14 15	7	12"	49'	1'- 2"	6"	15'-10"	11'- 8" 13'- 8" 15'- 8"	15'-7"	16'-3"	3"	A
	33'	TR - 15 - 33 - 400	10' 12' 14'	S A 3 - 10 15 S A 3 - 12 15 S A 3 - 14 15	9	24"	60'	1'- 2"	6"	15'-10"	11'- 8" 13'- 8" 15'- 8"	15'-7"	16'-3"	3"	A
	43'	TR - 15 - 43 - 400	10' 12' 14'	S A 3 - 10 15 S A 3 - 12 15 S A 3 - 14 15	11	24"	70'	1'- 2"	6"	15'-10"	11'- 8" 13'- 8" 15'- 8"	15'-7"	16'-3"	3"	A
	53'	TR - 15 - 53 - 400	10' 12' 14'	S A 4 - 10 15 S A 4 - 12 15 S A 4 - 14 15	12	36"	82'	1'- 2"	6"	15'-10"	11'- 8" 13'- 8" 15'- 8"	15'-7"	16'-3"	3"	A
	63'	TR - 15 - 63 - 400	10' 12' 14'	S A 4 - 10 15 S A 4 - 12 15 S A 4 - 14 15	14	36"	93'	1'- 2"	6"	15'-10"	11'- 8" 13'- 8" 15'- 8"	15'-7"	16'-3"	3"	A
	83'	TR - 15 - 83 - 400	10' 12' 14'	S A 5 - 10 15 S A 5 - 12 15 S A 5 - 14 15	17	54"	115'	1'- 2"	6"	15'-10"	11'- 8" 13'- 8" 15'- 8"	15'-7"	16'-3"	3"	A
	103'	TR - 15 - 103 - 400	10' 12' 14'	S A 6 - 10 15 S A 6 - 12 15 S A 6 - 14 15	21	54"	137'	1'- 2"	6"	15'-10"	11'- 8" 13'- 8" 15'- 8"	15'-7"	16'-3"	3"	A
	20'	23'	TR - 20 - 23 - 400	10' 12' 14'	S B 2 - 10 20 S B 2 - 12 20 S B 2 - 14 20	9	12"	54'	1'- 2"	8"	20'-10"	11'-10 1/8" 13'-10 1/8" 15'-10 1/8"	20'-7"	21'-3"	3"
33'		TR - 20 - 33 - 400	10' 12' 14'	S B 3 - 10 20 S B 3 - 12 20 S B 3 - 14 20	11	24"	65'	1'- 2"	8"	20'-10"	11'-10 1/8" 13'-10 1/8" 15'-10 1/8"	20'-7"	21'-3"	3"	A
43'		TR - 20 - 43 - 400	10' 12' 14'	S B 3 - 10 20 S B 3 - 12 20 S B 3 - 14 20	13	24"	75'	1'- 2"	8"	20'-10"	11'-10 1/8" 13'-10 1/8" 15'-10 1/8"	20'-7"	21'-3"	3"	A
53'		TR - 20 - 53 - 400	10' 12' 14'	S B 4 - 10 20 S B 4 - 12 20 S B 4 - 14 20	14	36"	87'	1'- 2"	8"	20'-10"	11'-10 1/8" 13'-10 1/8" 15'-10 1/8"	20'-7"	21'-3"	3"	A
63'		TR - 20 - 63 - 400	10' 12' 14'	S B 4 - 10 20 S B 4 - 12 20 S B 4 - 14 20	16	36"	98'	1'- 2"	8"	20'-10"	11'-10 1/8" 13'-10 1/8" 15'-10 1/8"	20'-7"	21'-3"	3"	A
83'		TR - 20 - 83 - 400	10' 12' 14'	S B 5 - 10 20 S B 5 - 12 20 S B 5 - 14 20	19	54"	120'	1'- 2"	8"	20'-10"	11'-10 1/8" 13'-10 1/8" 15'-10 1/8"	20'-7"	21'-3"	3"	A
103'		TR - 20 - 103 - 400	10' 12' 14'	S B 6 - 10 20 S B 6 - 12 20 S B 6 - 14 20	23	54"	142'	1'- 2"	8"	20'-10"	11'-10 1/8" 13'-10 1/8" 15'-10 1/8"	20'-7"	21'-3"	3"	A

20' - 0" MAXIMUM SUPPORT CENTERS

250 LB. CAPACITY

10' - 15' - 20' BRIDGE LENGTH

20' - 0" MAXIMUM SUPPORT CENTERS

250 LB.



BRIDGE CRANE KITS & STAND ALONE KITS

TR SERIES - FREE STANDING TRUSSED RUNWAY BRIDGE CRANE SYSTEMS

BL	RUNWAY LENGTH	BRIDGE & RUNWAY KIT NUMBER	TCH	SUPPORT KIT NUMBER	FESTOON DATA				DIMENSIONAL DATA						
					TROLLEY QTY	FTE	FCL	BRH	HEADER SIZE	HL	OAH	C/C	OAW	COL. SIZE	BASE DETAIL
23'	23'	TR-23 - 23 - 400	10' 12' 14'	S B 2 - 10 23 S B 2 - 12 23 S B 2 - 14 23	10	12"	58'	1'-2"	8"	23'-10"	11'-10 1/8" 13'-10 1/8" 15'-10 1/8"	23'-7"	24'-3"	3"	A
	33'	TR-23 - 33 - 400	10' 12' 14'	S B 3 - 10 23 S B 3 - 12 23 S B 3 - 14 23	12	24"	69'	1'-2"	8"	23'-10"	11'-10 1/8" 13'-10 1/8" 15'-10 1/8"	23'-7"	24'-3"	3"	A
	43'	TR-23 - 43 - 400	10' 12' 14'	S B 3 - 10 23 S B 3 - 12 23 S B 3 - 14 23	14	24"	79'	1'-2"	8"	23'-10"	11'-10 1/8" 13'-10 1/8" 15'-10 1/8"	23'-7"	24'-3"	3"	A
	53'	TR-23 - 53 - 400	10' 12' 14'	S B 4 - 10 23 S B 4 - 12 23 S B 4 - 14 23	15	36"	91'	1'-2"	8"	23'-10"	11'-10 1/8" 13'-10 1/8" 15'-10 1/8"	23'-7"	24'-3"	3"	A
	63'	TR-23 - 63 - 400	10' 12' 14'	S B 4 - 10 23 S B 4 - 12 23 S B 4 - 14 23	17	36"	102'	1'-2"	8"	23'-10"	11'-10 1/8" 13'-10 1/8" 15'-10 1/8"	23'-7"	24'-3"	3"	A
	83'	TR-23 - 83 - 400	10' 12' 14'	S B 5 - 10 23 S B 5 - 12 23 S B 5 - 14 23	20	54"	124'	1'-2"	8"	23'-10"	11'-10 1/8" 13'-10 1/8" 15'-10 1/8"	23'-7"	24'-3"	3"	A
	103'	TR-23 - 103 - 400	10' 12' 14'	S B 6 - 10 23 S B 6 - 12 23 S B 6 - 14 23	24	54"	146'	1'-2"	8"	23'-10"	11'-10 1/8" 13'-10 1/8" 15'-10 1/8"	23'-7"	24'-3"	3"	A
28'	23'	TR-28 - 23 - 400	10' 12' 14'	S B 2 - 10 28 S B 2 - 12 28 S B 2 - 14 28	11	12"	63'	1'-3 15/16"	8"	29'-6"	12'-0 1/16" 14'-0 1/16" 16'-0 1/16"	28'-8"	29'-6"	4"	B
	33'	TR-28 - 33 - 400	10' 12' 14'	S B 3 - 10 28 S B 3 - 12 28 S B 3 - 14 28	13	24"	74'	1'-3 15/16"	8"	29'-6"	12'-0 1/16" 14'-0 1/16" 16'-0 1/16"	28'-8"	29'-6"	4"	B
	43'	TR-28 - 43 - 400	10' 12' 14'	S B 3 - 10 28 S B 3 - 12 28 S B 3 - 14 28	15	24"	85'	1'-3 15/16"	8"	29'-6"	12'-0 1/16" 14'-0 1/16" 16'-0 1/16"	28'-8"	29'-6"	4"	B
	53'	TR-28 - 53 - 400	10' 12' 14'	S B 4 - 10 28 S B 4 - 12 28 S B 4 - 14 28	16	36"	96'	1'-3 15/16"	8"	29'-6"	12'-0 1/16" 14'-0 1/16" 16'-0 1/16"	28'-8"	29'-6"	4"	B
	63'	TR-28 - 63 - 400	10' 12' 14'	S B 4 - 10 28 S B 4 - 12 28 S B 4 - 14 28	18	36"	107'	1'-3 15/16"	8"	29'-6"	12'-0 1/16" 14'-0 1/16" 16'-0 1/16"	28'-8"	29'-6"	4"	B
	83'	TR-28 - 83 - 400	10' 12' 14'	S B 5 - 10 28 S B 5 - 12 28 S B 5 - 14 28	21	54"	129'	1'-3 15/16"	8"	29'-6"	12'-0 1/16" 14'-0 1/16" 16'-0 1/16"	28'-8"	29'-6"	4"	B
	103'	TR-28 - 103 - 400	10' 12' 14'	S B 6 - 10 28 S B 6 - 12 28 S B 6 - 14 28	25	54"	151'	1'-3 15/16"	8"	29'-6"	12'-0 1/16" 14'-0 1/16" 16'-0 1/16"	28'-8"	29'-6"	4"	B

20' - 0" MAXIMUM SUPPORT CENTERS

250 LB. CAPACITY

23' - 28' BRIDGE LENGTH

20' - 0" MAXIMUM SUPPORT CENTERS

250 LB.



BRIDGE CRANE KITS & STAND ALONE KITS

TR SERIES - FREE STANDING TRUSSED RUNWAY BRIDGE CRANE SYSTEMS

BL	RUNWAY LENGTH	BRIDGE & RUNWAY KIT NUMBER	TCH	SUPPORT KIT NUMBER	FESTOON DATA			DIMENSIONAL DATA							
					TROLLEY QTY	FTE	FCL	BRH	HEADER SIZE	HL	OAH	C/C	OAW	COL. SIZE	BASE DETAIL
10'	11.5'	TR - 10 - 11.5 - 500	10'	S C 2 - 10 10	5	12"	30'	1'-4 9/16"	6"	10'-10"	11'-10 9/16"	10'-7"	11'-3"	3"	A
			12'	S C 2 - 12 10						11'-6"	13'-10 9/16"	10'-8"	11'-6"	4"	B
			14'	S C 2 - 14 10						11'-6"	15'-10 9/16"	10'-8"	11'-6"	4"	B
	23'	TR - 10 - 23 - 500	10'	S C 2 - 10 10	6	12"	43'	1'-4 9/16"	6"	10'-10"	11'-10 9/16"	10'-7"	11'-3"	3"	A
			12'	S C 2 - 12 10						11'-6"	13'-10 9/16"	10'-8"	11'-6"	4"	B
			14'	S C 2 - 14 10						11'-6"	15'-10 9/16"	10'-8"	11'-6"	4"	B
	33'	TR - 10 - 33 - 500	10'	S C 3 - 10 10	8	24"	54'	1'-4 9/16"	6"	10'-10"	11'-10 9/16"	10'-7"	11'-3"	3"	A
			12'	S C 3 - 12 10						11'-6"	13'-10 9/16"	10'-8"	11'-6"	4"	B
14'			S C 3 - 14 10	11'-6"						15'-10 9/16"	10'-8"	11'-6"	4"	B	
43'	TR - 10 - 43 - 500	10'	S C 3 - 10 10	10	24"	64'	1'-4 9/16"	6"	10'-10"	11'-10 9/16"	10'-7"	11'-3"	3"	A	
		12'	S C 3 - 12 10						11'-6"	13'-10 9/16"	10'-8"	11'-6"	4"	B	
		14'	S C 3 - 14 10						11'-6"	15'-10 9/16"	10'-8"	11'-6"	4"	B	
53'	TR - 10 - 53 - 500	10'	S C 4 - 10 10	11	36"	76'	1'-4 9/16"	6"	10'-10"	11'-10 9/16"	10'-7"	11'-3"	3"	A	
		12'	S C 4 - 12 10						11'-6"	13'-10 9/16"	10'-8"	11'-6"	4"	B	
		14'	S C 4 - 14 10						11'-6"	15'-10 9/16"	10'-8"	11'-6"	4"	B	
63'	TR - 10 - 63 - 500	10'	S C 4 - 10 10	13	36"	87'	1'-4 9/16"	6"	10'-10"	11'-10 9/16"	10'-7"	11'-3"	3"	A	
		12'	S C 4 - 12 10						11'-6"	13'-10 9/16"	10'-8"	11'-6"	4"	B	
		14'	S C 4 - 14 10						11'-6"	15'-10 9/16"	10'-8"	11'-6"	4"	B	
83'	TR - 10 - 83 - 500	10'	S C 5 - 10 10	16	54"	109'	1'-4 9/16"	6"	10'-10"	11'-10 9/16"	10'-7"	11'-3"	3"	A	
		12'	S C 5 - 12 10						11'-6"	13'-10 9/16"	10'-8"	11'-6"	4"	B	
		14'	S C 5 - 14 10						11'-6"	15'-10 9/16"	10'-8"	11'-6"	4"	B	
103'	TR - 10 - 103 - 500	10'	S C 6 - 10 10	20	54"	131'	1'-4 9/16"	6"	10'-10"	11'-10 9/16"	10'-7"	11'-3"	3"	A	
		12'	S C 6 - 12 10						11'-6"	13'-10 9/16"	10'-8"	11'-6"	4"	B	
		14'	S C 6 - 14 10						11'-6"	15'-10 9/16"	10'-8"	11'-6"	4"	B	
15'	23'	TR - 15 - 23 - 500	10'	S C 2 - 10 15	7	12"	49'	1'-4 9/16"	6"	15'-10"	11'-10 9/16"	15'-7"	16'-3"	3"	A
			12'	S C 2 - 12 15						16'-6"	13'-10 9/16"	15'-8"	16'-6"	4"	B
			14'	S C 2 - 14 15						16'-6"	15'-10 9/16"	15'-8"	16'-6"	4"	B
	33'	TR - 15 - 33 - 500	10'	S C 3 - 10 15	9	24"	60'	1'-4 9/16"	6"	15'-10"	11'-10 9/16"	15'-7"	16'-3"	3"	A
			12'	S C 3 - 12 15						16'-6"	13'-10 9/16"	15'-8"	16'-6"	4"	B
			14'	S C 3 - 14 15						16'-6"	15'-10 9/16"	15'-8"	16'-6"	4"	B
	43'	TR - 15 - 43 - 500	10'	S C 3 - 10 15	11	24"	70'	1'-4 9/16"	6"	15'-10"	11'-10 9/16"	15'-7"	16'-3"	3"	A
			12'	S C 3 - 12 15						16'-6"	13'-10 9/16"	15'-8"	16'-6"	4"	B
14'			S C 3 - 14 15	16'-6"						15'-10 9/16"	15'-8"	16'-6"	4"	B	
53'	TR - 15 - 53 - 500	10'	S C 4 - 10 15	12	36"	82'	1'-4 9/16"	6"	15'-10"	11'-10 9/16"	15'-7"	16'-3"	3"	A	
		12'	S C 4 - 12 15						16'-6"	13'-10 9/16"	15'-8"	16'-6"	4"	B	
		14'	S C 4 - 14 15						16'-6"	15'-10 9/16"	15'-8"	16'-6"	4"	B	
63'	TR - 15 - 63 - 500	10'	S C 4 - 10 15	14	36"	93'	1'-4 9/16"	6"	15'-10"	11'-10 9/16"	15'-7"	16'-3"	3"	A	
		12'	S C 4 - 12 15						16'-6"	13'-10 9/16"	15'-8"	16'-6"	4"	B	
		14'	S C 4 - 14 15						16'-6"	15'-10 9/16"	15'-8"	16'-6"	4"	B	
83'	TR - 15 - 83 - 500	10'	S C 5 - 10 15	17	54"	115'	1'-4 9/16"	6"	15'-10"	11'-10 9/16"	15'-7"	16'-3"	3"	A	
		12'	S C 5 - 12 15						16'-6"	13'-10 9/16"	15'-8"	16'-6"	4"	B	
		14'	S C 5 - 14 15						16'-6"	15'-10 9/16"	15'-8"	16'-6"	4"	B	
103'	TR - 15 - 103 - 500	10'	S C 6 - 10 15	21	54"	137'	1'-4 9/16"	6"	15'-10"	11'-10 9/16"	15'-7"	16'-3"	3"	A	
		12'	S C 6 - 12 15						16'-6"	13'-10 9/16"	15'-8"	16'-6"	4"	B	
		14'	S C 6 - 14 15						16'-6"	15'-10 9/16"	15'-7"	16'-6"	4"	B	
20'	23'	TR - 20 - 23 - 500	10'	S D 2 - 10 20	9	12"	54'	1'-4 9/16"	8"	20'-10"	12'-0 11/16"	20'-7"	21'-3"	3"	A
			12'	S D 2 - 12 20						21'-6"	14'-0 11/16"	20'-8"	21'-6"	4"	B
			14'	S D 2 - 14 20						21'-6"	16'-0 11/16"	20'-8"	21'-6"	4"	B
	33'	TR - 20 - 33 - 500	10'	S D 3 - 10 20	11	24"	65'	1'-4 9/16"	8"	20'-10"	12'-0 11/16"	20'-7"	21'-3"	3"	A
			12'	S D 3 - 12 20						21'-6"	14'-0 11/16"	20'-8"	21'-6"	4"	B
			14'	S D 3 - 14 20						21'-6"	16'-0 11/16"	20'-8"	21'-6"	4"	B
	43'	TR - 20 - 43 - 500	10'	S D 3 - 10 20	13	24"	75'	1'-4 9/16"	8"	20'-10"	12'-0 11/16"	20'-7"	21'-3"	3"	A
			12'	S D 3 - 12 20						21'-6"	14'-0 11/16"	20'-8"	21'-6"	4"	B
14'			S D 3 - 14 20	21'-6"						16'-0 11/16"	20'-8"	21'-6"	4"	B	
53'	TR - 20 - 53 - 500	10'	S D 4 - 10 20	14	36"	87'	1'-4 9/16"	8"	20'-10"	12'-0 11/16"	20'-7"	21'-3"	3"	A	
		12'	S D 4 - 12 20						21'-6"	14'-0 11/16"	20'-8"	21'-6"	4"	B	
		14'	S D 4 - 14 20						21'-6"	16'-0 11/16"	20'-8"	21'-6"	4"	B	
63'	TR - 20 - 63 - 500	10'	S D 4 - 10 20	16	36"	98'	1'-4 9/16"	8"	20'-10"	12'-0 11/16"	20'-7"	21'-3"	3"	A	
		12'	S D 4 - 12 20						21'-6"	14'-0 11/16"	20'-8"	21'-6"	4"	B	
		14'	S D 4 - 14 20						21'-6"	16'-0 11/16"	20'-8"	21'-6"	4"	B	
83'	TR - 20 - 83 - 500	10'	S D 5 - 10 20	19	54"	120'	1'-4 9/16"	8"	20'-10"	12'-0 11/16"	20'-7"	21'-3"	3"	A	
		12'	S D 5 - 12 20						21'-6"	14'-0 11/16"	20'-8"	21'-6"	4"	B	
		14'	S D 5 - 14 20						21'-6"	16'-0 11/16"	20'-8"	21'-6"	4"	B	
103'	TR - 20 - 103 - 500	10'	S D 6 - 10 20	23	54"	142'	1'-4 9/16"	8"	20'-10"	12'-0 11/16"	20'-7"	21'-3"	3"	A	
		12'	S D 6 - 12 20						21'-6"	14'-0 11/16"	20'-8"	21'-6"	4"	B	
		14'	S D 6 - 14 20						21'-6"	16'-0 11/16"	20'-8"	21'-6"	4"	B	

20' - 0" MAXIMUM SUPPORT CENTERS

500 LB. CAPACITY

10' - 15' - 20' BRIDGE LENGTH

20' - 0" MAXIMUM SUPPORT CENTERS

500 LB.



BRIDGE CRANE KITS & STAND ALONE KITS

TR SERIES - FREE STANDING TRUSSED RUNWAY BRIDGE CRANE SYSTEMS

BL	RUNWAY LENGTH	BRIDGE & RUNWAY KIT NUMBER	TCH	SUPPORT KIT NUMBER	FESTOON DATA			DIMENSIONAL DATA							
					TROLLEY QTY	FTE	FCL	BRH	HEADER SIZE	HL	OAH	C/C	OAW	COL. SIZE	BASE DETAIL
23'	23'	TR - 23 - 23 - 500	10'	S D 2 - 10 23	10	12"	58'	1'-4 9/16"	8"	23'-10"	12'-0 11/16"	23'-7"	24'-3"	3"	A
			12'	S D 2 - 12 23						24'-6"	14'-0 11/16"	23'-8"	24'-6"	4"	B
			14'	S D 2 - 14 23						24'-6"	16'-0 11/16"	23'-8"	24'-6"	4"	B
	33'	TR - 23 - 33 - 500	10'	S D 3 - 10 23	12	24"	69'	1'-4 9/16"	8"	23'-10"	12'-0 11/16"	23'-7"	24'-3"	3"	A
			12'	S D 3 - 12 23						24'-6"	14'-0 11/16"	23'-8"	24'-6"	4"	B
			14'	S D 3 - 14 23						24'-6"	16'-0 11/16"	23'-8"	24'-6"	4"	B
	43'	TR - 23 - 43 - 500	10'	S D 3 - 10 23	14	24"	79'	1'-4 9/16"	8"	23'-10"	12'-0 11/16"	23'-7"	24'-3"	3"	A
12'			S D 3 - 12 23	24'-6"						14'-0 11/16"	23'-8"	24'-6"	4"	B	
14'			S D 3 - 14 23	24'-6"						16'-0 11/16"	23'-8"	24'-6"	4"	B	
53'	TR - 23 - 53 - 500	10'	S D 4 - 10 23	15	36"	91'	1'-4 9/16"	8"	23'-10"	12'-0 11/16"	23'-7"	24'-3"	3"	A	
		12'	S D 4 - 12 23						24'-6"	14'-0 11/16"	23'-8"	24'-6"	4"	B	
		14'	S D 4 - 14 23						24'-6"	16'-0 11/16"	23'-8"	24'-6"	4"	B	
63'	TR - 23 - 63 - 500	10'	S D 4 - 10 23	17	36"	102'	1'-4 9/16"	8"	23'-10"	12'-0 11/16"	23'-7"	24'-3"	3"	A	
		12'	S D 4 - 12 23						24'-6"	14'-0 11/16"	23'-8"	24'-6"	4"	B	
		14'	S D 4 - 14 23						24'-6"	16'-0 11/16"	23'-8"	24'-6"	4"	B	
83'	TR - 23 - 83 - 500	10'	S D 5 - 10 23	20	54"	124'	1'-4 9/16"	8"	23'-10"	12'-0 11/16"	23'-7"	24'-3"	3"	A	
		12'	S D 5 - 12 23						24'-6"	14'-0 11/16"	23'-8"	24'-6"	4"	B	
		14'	S D 5 - 14 23						24'-6"	16'-0 11/16"	23'-8"	24'-6"	4"	B	
103'	TR - 23 - 103 - 500	10'	S D 6 - 10 23	24	54"	146'	1'-4 9/16"	8"	23'-10"	12'-0 11/16"	23'-7"	24'-3"	3"	A	
		12'	S D 6 - 12 23						24'-6"	14'-0 11/16"	23'-8"	24'-6"	4"	B	
		14'	S D 6 - 14 23						24'-6"	16'-0 11/16"	23'-8"	24'-6"	4"	B	
28'	23'	TR - 28 - 23 - 500	10'	S P 2 - 10 28	11	12"	63'	1'-6 3/8"	10"	29'-6"	12'-4 1/2"	28'-8"	29'-6"	4"	B
			12'	S P 2 - 12 28						29'-6"	14'-4 1/2"	28'-8"	29'-6"	4"	B
			14'	S P 2 - 14 28						29'-6"	16'-4 1/2"	28'-8"	29'-6"	4"	B
	33'	TR - 28 - 33 - 500	10'	S P 3 - 10 28	13	24"	74'	1'-6 3/8"	10"	29'-6"	12'-4 1/2"	28'-8"	29'-6"	4"	B
			12'	S P 3 - 12 28						29'-6"	14'-4 1/2"	28'-8"	29'-6"	4"	B
			14'	S P 3 - 14 28						29'-6"	16'-4 1/2"	28'-8"	29'-6"	4"	B
	43'	TR - 28 - 43 - 500	10'	S P 3 - 10 28	15	24"	85'	1'-6 3/8"	10"	29'-6"	12'-4 1/2"	28'-8"	29'-6"	4"	B
12'			S P 3 - 12 28	29'-6"						14'-4 1/2"	28'-8"	29'-6"	4"	B	
14'			S P 3 - 14 28	29'-6"						16'-4 1/2"	28'-8"	29'-6"	4"	B	
53'	TR - 28 - 53 - 500	10'	S P 4 - 10 28	16	36"	96'	1'-6 3/8"	10"	29'-6"	12'-4 1/2"	28'-8"	29'-6"	4"	B	
		12'	S P 4 - 12 28						29'-6"	14'-4 1/2"	28'-8"	29'-6"	4"	B	
		14'	S P 4 - 14 28						29'-6"	16'-4 1/2"	28'-8"	29'-6"	4"	B	
63'	TR - 28 - 63 - 500	10'	S P 4 - 10 28	18	36"	107'	1'-6 3/8"	10"	29'-6"	12'-4 1/2"	28'-8"	29'-6"	4"	B	
		12'	S P 4 - 12 28						29'-6"	14'-4 1/2"	28'-8"	29'-6"	4"	B	
		14'	S P 4 - 14 28						29'-6"	16'-4 1/2"	28'-8"	29'-6"	4"	B	
83'	TR - 28 - 83 - 500	10'	S P 5 - 10 28	21	54"	129'	1'-6 3/8"	10"	29'-6"	12'-4 1/2"	28'-8"	29'-6"	4"	B	
		12'	S P 5 - 12 28						29'-6"	14'-4 1/2"	28'-8"	29'-6"	4"	B	
		14'	S P 5 - 14 28						29'-6"	16'-4 1/2"	28'-8"	29'-6"	4"	B	
103'	TR - 28 - 103 - 500	10'	S P 6 - 10 28	25	54"	151'	1'-6 3/8"	10"	29'-6"	12'-4 1/2"	28'-8"	29'-6"	4"	B	
		12'	S P 6 - 12 28						29'-6"	14'-4 1/2"	28'-8"	29'-6"	4"	B	
		14'	S P 6 - 14 28						29'-6"	16'-4 1/2"	28'-8"	29'-6"	4"	B	
34'	23'	TR - 34 - 23 - 500	10'	S O 2 - 10 34	14	12"	70'	1'-8 3/4"	10"	35'-6"	12'-6 7/8"	34'-8"	35'-6"	4"	B
			12'	S O 2 - 12 34						35'-6"	14'-6 7/8"	34'-8"	35'-6"	4"	B
			14'	S O 2 - 14 34						35'-6"	16'-6 7/8"	34'-8"	35'-6"	4"	B
	33'	TR - 34 - 33 - 500	10'	S O 3 - 10 34	16	24"	81'	1'-8 3/4"	10"	35'-6"	12'-6 7/8"	34'-8"	35'-6"	4"	B
			12'	S O 3 - 12 34						35'-6"	14'-6 7/8"	34'-8"	35'-6"	4"	B
			14'	S O 3 - 14 34						35'-6"	16'-6 7/8"	34'-8"	35'-6"	4"	B
	43'	TR - 34 - 43 - 500	10'	S O 3 - 10 34	18	24"	91'	1'-8 3/4"	10"	35'-6"	12'-6 7/8"	34'-8"	35'-6"	4"	B
			12'	S O 3 - 12 34						35'-6"	14'-6 7/8"	34'-8"	35'-6"	4"	B
			14'	S O 3 - 14 34						35'-6"	16'-6 7/8"	34'-8"	35'-6"	4"	B
	53'	TR - 34 - 53 - 500	10'	S O 4 - 10 34	19	36"	103'	1'-8 3/4"	10"	35'-6"	12'-6 7/8"	34'-8"	35'-6"	4"	B
			12'	S O 4 - 12 34						35'-6"	14'-6 7/8"	34'-8"	35'-6"	4"	B
			14'	S O 4 - 14 34						35'-6"	16'-6 7/8"	34'-8"	35'-6"	4"	B
	63'	TR - 34 - 63 - 500	10'	S O 4 - 10 34	21	36"	114'	1'-8 3/4"	10"	35'-6"	12'-6 7/8"	34'-8"	35'-6"	4"	B
			12'	S O 4 - 12 34						35'-6"	14'-6 7/8"	34'-8"	35'-6"	4"	B
14'			S O 4 - 14 34	35'-6"						16'-6 7/8"	34'-8"	35'-6"	4"	B	
83'	TR - 34 - 83 - 500	10'	S O 5 - 10 34	24	54"	136'	1'-8 3/4"	10"	35'-6"	12'-6 7/8"	34'-8"	35'-6"	4"	B	
		12'	S O 5 - 12 34						35'-6"	14'-6 7/8"	34'-8"	35'-6"	4"	B	
		14'	S O 5 - 14 34						35'-6"	16'-6 7/8"	34'-8"	35'-6"	4"	B	
103'	TR - 34 - 103 - 500	10'	S O 6 - 10 34	26	54"	158'	1'-8 3/4"	10"	35'-6"	12'-6 7/8"	34'-8"	35'-6"	4"	B	
		12'	S O 6 - 12 34						35'-6"	14'-6 7/8"	34'-8"	35'-6"	4"	B	
		14'	S O 6 - 14 34						35'-6"	16'-6 7/8"	34'-8"	35'-6"	4"	B	

20' - 0" MAXIMUM SUPPORT CENTERS

500 LB. CAPACITY

23' - 28' - 34' BRIDGE LENGTH

20' - 0" MAXIMUM SUPPORT CENTERS

500 LB.



BRIDGE CRANE KITS & STAND ALONE KITS

TR SERIES - FREE STANDING TRUSSED RUNWAY BRIDGE CRANE SYSTEMS

BL	RUNWAY LENGTH	BRIDGE & RUNWAY KIT NUMBER	TCH	SUPPORT KIT NUMBER	FESTOON DATA			DIMENSIONAL DATA							
					TROLLEY QTY	FTE	FCL	BRH	HEADER SIZE	HL	OAH	C/C	OAW	COL. SIZE	BASE DETAIL
10'	11.5'	TR - 10 - 11.5 - 600	10'	S E 2 - 10 10	5	12"	30'	1'-6 5/8"	8"	11'-6"	12'-2 5/8"	10'-8"	11'-6"	4"	B
			12'	S E 2 - 12 10						11'-6"	14'-2 5/8"	10'-8"	11'-6"	4"	B
			14'	S E 2 - 14 10						11'-7"	16'-2 5/8"	10'-9"	11'-7"	5"	C
	23'	TR - 10 - 23 - 600	10'	S E 2 - 10 10	6	12"	43'	1'-6 5/8"	8"	11'-6"	12'-2 5/8"	10'-8"	11'-6"	4"	B
			12'	S E 2 - 12 10						11'-6"	14'-2 5/8"	10'-8"	11'-6"	4"	B
			14'	S E 2 - 14 10						11'-7"	16'-2 5/8"	10'-9"	11'-7"	5"	C
	33'	TR - 10 - 33 - 600	10'	S E 3 - 10 10	8	24"	54'	1'-6 5/8"	8"	11'-6"	12'-2 5/8"	10'-8"	11'-6"	4"	B
			12'	S E 3 - 12 10						11'-6"	14'-2 5/8"	10'-8"	11'-6"	4"	B
14'			S E 3 - 14 10	11'-7"						16'-2 5/16"	10'-9"	11'-7"	5"	C	
43'	TR - 10 - 43 - 600	10'	S E 3 - 10 10	10	24"	64'	1'-6 5/8"	8"	11'-6"	12'-2 5/8"	10'-8"	11'-6"	4"	B	
		12'	S E 3 - 12 10						11'-6"	14'-2 5/8"	10'-8"	11'-6"	4"	B	
		14'	S E 3 - 14 10						11'-7"	16'-2 5/8"	10'-9"	11'-7"	5"	C	
53'	TR - 10 - 53 - 600	10'	S E 4 - 10 10	11	36"	76'	1'-6 5/8"	8"	11'-6"	12'-2 5/8"	10'-8"	11'-6"	4"	B	
		12'	S E 4 - 12 10						11'-6"	14'-2 5/8"	10'-8"	11'-6"	4"	B	
		14'	S E 4 - 14 10						11'-7"	16'-2 5/8"	10'-9"	11'-7"	5"	C	
63'	TR - 10 - 63 - 600	10'	S E 4 - 10 10	13	36"	87'	1'-6 5/8"	8"	11'-6"	12'-2 5/8"	10'-8"	11'-6"	4"	B	
		12'	S E 4 - 12 10						11'-6"	14'-2 5/8"	10'-8"	11'-6"	4"	B	
		14'	S E 4 - 14 10						11'-7"	16'-2 5/8"	10'-9"	11'-7"	5"	C	
83'	TR - 10 - 83 - 600	10'	S E 5 - 10 10	16	54"	109'	1'-6 5/8"	8"	11'-6"	12'-2 5/8"	10'-8"	11'-6"	4"	B	
		12'	S E 5 - 12 10						11'-6"	14'-2 5/8"	10'-8"	11'-6"	4"	B	
		14'	S E 5 - 14 10						11'-7"	16'-2 5/8"	10'-9"	11'-7"	5"	C	
103'	TR - 10 - 103 - 600	10'	S E 6 - 10 10	20	54"	131'	1'-6 5/8"	8"	11'-6"	12'-2 5/8"	10'-8"	11'-6"	4"	B	
		12'	S E 6 - 12 10						11'-6"	14'-2 5/8"	10'-8"	11'-6"	4"	B	
		14'	S E 6 - 14 10						11'-7"	16'-2 5/8"	10'-9"	11'-7"	5"	C	
15'	23'	TR - 15 - 23 - 600	10'	S E 2 - 10 15	7	12"	49'	1'-6 5/8"	8"	16'-6"	12'-2 5/8"	15'-8"	16'-6"	4"	B
			12'	S E 2 - 12 15						16'-6"	14'-2 5/8"	15'-8"	16'-6"	4"	B
			14'	S E 2 - 14 15						16'-7"	16'-2 5/8"	15'-9"	16'-7"	5"	C
	33'	TR - 15 - 33 - 600	10'	S E 3 - 10 15	9	24"	60'	1'-6 5/8"	8"	16'-6"	12'-2 5/8"	15'-8"	16'-6"	4"	B
			12'	S E 3 - 12 15						16'-6"	14'-2 5/8"	15'-8"	16'-6"	4"	B
			14'	S E 3 - 14 15						16'-7"	16'-2 5/8"	15'-9"	16'-7"	5"	C
	43'	TR - 15 - 43 - 600	10'	S E 3 - 10 15	11	24"	70'	1'-6 5/8"	8"	16'-6"	12'-2 5/8"	15'-8"	16'-6"	4"	B
			12'	S E 3 - 12 15						16'-6"	14'-2 5/8"	15'-8"	16'-6"	4"	B
14'			S E 3 - 14 15	16'-7"						16'-2 5/8"	15'-9"	16'-7"	5"	C	
53'	TR - 15 - 53 - 600	10'	S E 4 - 10 15	12	36"	82'	1'-6 5/8"	8"	16'-6"	12'-2 5/8"	15'-8"	16'-6"	4"	B	
		12'	S E 4 - 12 15						16'-6"	14'-2 5/8"	15'-8"	16'-6"	4"	B	
		14'	S E 4 - 14 15						16'-7"	16'-2 5/8"	15'-9"	16'-7"	5"	C	
63'	TR - 15 - 63 - 600	10'	S E 4 - 10 15	14	36"	93'	1'-6 5/8"	8"	16'-6"	12'-2 5/8"	15'-8"	16'-6"	4"	B	
		12'	S E 4 - 12 15						16'-6"	14'-2 5/8"	15'-8"	16'-6"	4"	B	
		14'	S E 4 - 14 15						16'-7"	16'-2 5/8"	15'-9"	16'-7"	5"	C	
83'	TR - 15 - 83 - 600	10'	S E 5 - 10 15	17	54"	115'	1'-6 5/8"	8"	16'-6"	12'-2 5/8"	15'-8"	16'-6"	4"	B	
		12'	S E 5 - 12 15						16'-6"	14'-2 5/8"	15'-8"	16'-6"	4"	B	
		14'	S E 5 - 14 15						16'-7"	16'-2 5/8"	15'-9"	16'-7"	5"	C	
103'	TR - 15 - 103 - 600	10'	S E 6 - 10 15	21	54"	137'	1'-6 5/8"	8"	16'-6"	12'-2 5/8"	15'-8"	16'-6"	4"	B	
		12'	S E 6 - 12 15						16'-6"	14'-2 5/8"	15'-8"	16'-6"	4"	B	
		14'	S E 6 - 14 15						16'-7"	16'-2 5/8"	15'-9"	16'-7"	5"	C	
20'	23'	TR - 20 - 23 - 600	10'	S F 2 - 10 20	9	12"	54'	1'-6 5/8"	8"	21'-6"	12'-2 3/4"	20'-8"	21'-6"	4"	B
			12'	S F 2 - 12 20						21'-6"	14'-2 3/4"	20'-8"	21'-6"	4"	B
			14'	S F 2 - 14 20						21'-7"	16'-2 3/4"	20'-9"	21'-7"	5"	C
	33'	TR - 20 - 33 - 600	10'	S F 3 - 10 20	11	24"	65'	1'-6 5/8"	8"	21'-6"	12'-2 3/4"	20'-8"	21'-6"	4"	B
			12'	S F 3 - 12 20						21'-6"	14'-2 3/4"	20'-8"	21'-6"	4"	B
			14'	S F 3 - 14 20						21'-7"	16'-2 3/4"	20'-9"	21'-7"	5"	C
	43'	TR - 20 - 43 - 600	10'	S F 3 - 10 20	13	24"	75'	1'-6 5/8"	8"	21'-6"	12'-2 3/4"	20'-8"	21'-6"	4"	B
			12'	S F 3 - 12 20						21'-6"	14'-2 3/4"	20'-8"	21'-6"	4"	B
14'			S F 3 - 14 20	21'-7"						16'-2 3/4"	20'-9"	21'-7"	5"	C	
53'	TR - 20 - 53 - 600	10'	S F 4 - 10 20	14	36"	87'	1'-6 5/8"	8"	21'-6"	12'-2 3/4"	20'-8"	21'-6"	4"	B	
		12'	S F 4 - 12 20						21'-6"	14'-2 3/4"	20'-8"	21'-6"	4"	B	
		14'	S F 4 - 14 20						21'-7"	16'-2 3/4"	20'-9"	21'-7"	5"	C	
63'	TR - 20 - 63 - 600	10'	S F 4 - 10 20	16	36"	98'	1'-6 5/8"	8"	21'-6"	12'-2 3/4"	20'-8"	21'-6"	4"	B	
		12'	S F 4 - 12 20						21'-6"	14'-2 3/4"	20'-8"	21'-6"	4"	B	
		14'	S F 4 - 14 20						21'-7"	16'-2 3/4"	20'-9"	21'-7"	5"	C	
83'	TR - 20 - 83 - 600	10'	S F 5 - 10 20	19	54"	120'	1'-6 5/8"	8"	21'-6"	12'-2 3/4"	20'-8"	21'-6"	4"	B	
		12'	S F 5 - 12 20						21'-6"	14'-2 3/4"	20'-8"	21'-6"	4"	B	
		14'	S F 5 - 14 20						21'-7"	16'-2 3/4"	20'-9"	21'-7"	5"	C	
103'	TR - 20 - 103 - 600	10'	S F 6 - 10 20	23	54"	142'	1'-6 5/8"	8"	21'-6"	12'-2 3/4"	20'-8"	21'-6"	4"	B	
		12'	S F 6 - 12 20						21'-6"	14'-2 3/4"	20'-8"	21'-6"	4"	B	
		14'	S F 6 - 14 20						21'-7"	16'-2 3/4"	20'-9"	21'-7"	5"	C	

20' - 0" MAXIMUM SUPPORT CENTERS

1,000 LB. CAPACITY

10' - 15' - 20' BRIDGE LENGTH

20' - 0" MAXIMUM SUPPORT CENTERS

1,000



BRIDGE CRANE KITS & STAND ALONE KITS

TR SERIES - FREE STANDING TRUSSED RUNWAY BRIDGE CRANE SYSTEMS

BL	RUNWAY LENGTH	BRIDGE & RUNWAY KIT NUMBER	TCH	SUPPORT KIT NUMBER	FESTOON DATA				DIMENSIONAL DATA						
					TROLLEY QTY	FTE	FCL	BRH	HEADER SIZE	HL	OAH	C/C	OAW	COL. SIZE	BASE DETAIL
23'	23'	TR-23-23-600	10'	S F 2 - 10 23	10	12"	58'	1'-6 5/8"	8"	24'-6"	12'-2 3/4"	23'-8"	24'-6"	4"	B
			12'	S F 2 - 12 23						24'-6"	14'-2 3/4"	23'-8"	24'-6"	4"	B
			14'	S F 2 - 14 23						24'-7"	16'-2 3/4"	23'-9"	24'-7"	5"	C
	33'	TR-23-33-600	10'	S F 3 - 10 23	12	24"	69'	1'-6 5/8"	8"	24'-6"	12'-2 3/4"	23'-8"	24'-6"	4"	B
			12'	S F 3 - 12 23						24'-6"	14'-2 3/4"	23'-8"	24'-6"	4"	B
			14'	S F 3 - 14 23						24'-7"	16'-2 3/4"	23'-9"	24'-7"	5"	C
	43'	TR-23-43-600	10'	S F 3 - 10 23	14	24"	79'	1'-6 5/8"	8"	24'-6"	12'-2 3/4"	23'-8"	24'-6"	4"	B
12'			S F 3 - 12 23	24'-6"						14'-2 3/4"	23'-8"	24'-6"	4"	B	
14'			S F 3 - 14 23	24'-7"						16'-2 3/4"	23'-9"	24'-7"	5"	C	
53'	TR-23-53-600	10'	S F 4 - 10 23	15	36"	91'	1'-6 5/8"	8"	24'-6"	12'-2 3/4"	23'-8"	24'-6"	4"	B	
		12'	S F 4 - 12 23						24'-6"	14'-2 3/4"	23'-8"	24'-6"	4"	B	
		14'	S F 4 - 14 23						24'-7"	16'-2 3/4"	23'-9"	24'-7"	5"	C	
63'	TR-23-63-600	10'	S F 4 - 10 23	17	36"	102'	1'-6 5/8"	8"	24'-6"	12'-2 3/4"	23'-8"	24'-6"	4"	B	
		12'	S F 4 - 12 23						24'-6"	14'-2 3/4"	23'-8"	24'-6"	4"	B	
		14'	S F 4 - 14 23						24'-7"	16'-2 3/4"	23'-9"	24'-7"	5"	C	
83'	TR-23-83-600	10'	S F 5 - 10 23	20	54"	124'	1'-6 5/8"	8"	24'-6"	12'-2 3/4"	23'-8"	24'-6"	4"	B	
		12'	S F 5 - 12 23						24'-6"	14'-2 3/4"	23'-8"	24'-6"	4"	B	
		14'	S F 5 - 14 23						24'-7"	16'-2 3/4"	23'-9"	24'-7"	5"	C	
103'	TR-23-103-600	10'	S F 6 - 10 23	24	54"	146'	1'-6 5/8"	8"	24'-6"	12'-2 3/4"	23'-8"	24'-6"	4"	B	
		12'	S F 6 - 12 23						24'-6"	14'-2 3/4"	23'-8"	24'-6"	4"	B	
		14'	S F 6 - 14 23						24'-7"	16'-2 3/4"	23'-9"	24'-7"	5"	C	
28'	23'	TR-28-23-600	10'	S Q 2 - 10 28	11	12"	63'	1'-8 1/2"	10"	29'-6"	12'-6 5/8"	28'-8"	29'-6"	4"	B
			12'	S Q 2 - 12 28						29'-6"	14'-6 5/8"	28'-8"	29'-6"	4"	B
			14'	S Q 2 - 14 28						29'-7"	16'-6 5/8"	28'-9"	29'-7"	5"	C
	33'	TR-28-33-600	10'	S Q 3 - 10 28	13	24"	74'	1'-8 1/2"	10"	29'-6"	12'-6 5/8"	28'-8"	29'-6"	4"	B
			12'	S Q 3 - 12 28						29'-6"	14'-6 5/8"	28'-8"	29'-6"	4"	B
			14'	S Q 3 - 14 28						29'-7"	16'-6 5/8"	28'-9"	29'-7"	5"	C
	43'	TR-28-43-600	10'	S Q 3 - 10 28	15	24"	85'	1'-8 1/2"	10"	29'-6"	12'-6 5/8"	28'-8"	29'-6"	4"	B
12'			S Q 3 - 12 28	29'-6"						14'-6 5/8"	28'-8"	29'-6"	4"	B	
14'			S Q 3 - 14 28	29'-7"						16'-6 5/8"	28'-9"	29'-7"	5"	C	
53'	TR-28-53-600	10'	S Q 4 - 10 28	16	36"	96'	1'-8 1/2"	10"	29'-6"	12'-6 5/8"	28'-8"	29'-6"	4"	B	
		12'	S Q 4 - 12 28						29'-6"	14'-6 5/8"	28'-8"	29'-6"	4"	B	
		14'	S Q 4 - 14 28						29'-7"	16'-6 5/8"	28'-9"	29'-7"	5"	C	
63'	TR-28-63-600	10'	S Q 4 - 10 28	18	36"	107'	1'-8 1/2"	10"	29'-6"	12'-6 5/8"	28'-8"	29'-6"	4"	B	
		12'	S Q 4 - 12 28						29'-6"	14'-6 5/8"	28'-8"	29'-6"	4"	B	
		14'	S Q 4 - 14 28						29'-7"	16'-6 5/8"	28'-9"	29'-7"	5"	C	
83'	TR-28-83-600	10'	S Q 5 - 10 28	21	54"	129'	1'-8 1/2"	10"	29'-6"	12'-6 5/8"	28'-8"	29'-6"	4"	B	
		12'	S Q 5 - 12 28						29'-6"	14'-6 5/8"	28'-8"	29'-6"	4"	B	
		14'	S Q 5 - 14 28						29'-7"	16'-6 5/8"	28'-9"	29'-7"	5"	C	
103'	TR-28-103-600	10'	S Q 6 - 10 28	25	54"	151'	1'-8 1/2"	10"	29'-6"	12'-6 5/8"	28'-8"	29'-6"	4"	B	
		12'	S Q 6 - 12 28						29'-6"	14'-6 5/8"	28'-8"	29'-6"	4"	B	
		14'	S Q 6 - 14 28						29'-7"	16'-6 5/8"	28'-9"	29'-7"	5"	C	
34'	23'	TR-34-23-600	10'	S R 2 - 10 34	14	12"	70'	1'-11 3/8"	12"	35'-6"	12'-11 5/8"	34'-8"	35'-6"	4"	B
			12'	S R 2 - 12 34						35'-6"	14'-11 5/8"	34'-8"	35'-6"	4"	B
			14'	S R 2 - 14 34						35'-7"	16'-11 5/8"	34'-9"	35'-7"	5"	C
	33'	TR-34-33-600	10'	S R 3 - 10 34	16	24"	81'	1'-11 3/8"	12"	35'-6"	12'-11 5/8"	34'-8"	35'-6"	4"	B
			12'	S R 3 - 12 34						35'-6"	14'-11 5/8"	34'-8"	35'-6"	4"	B
			14'	S R 3 - 14 34						35'-7"	16'-11 5/8"	34'-9"	35'-7"	5"	C
	43'	TR-34-43-600	10'	S R 3 - 10 34	19	24"	91'	1'-11 3/8"	12"	35'-6"	12'-11 5/8"	34'-8"	35'-6"	4"	B
			12'	S R 3 - 12 34						35'-6"	14'-11 5/8"	34'-8"	35'-6"	4"	B
			14'	S R 3 - 14 34						35'-7"	16'-11 5/8"	34'-9"	35'-7"	5"	C
	53'	TR-34-53-600	10'	S R 4 - 10 34	19	36"	103'	1'-11 3/8"	12"	35'-6"	12'-11 5/8"	34'-8"	35'-6"	4"	B
			12'	S R 4 - 12 34						35'-6"	14'-11 5/8"	34'-8"	35'-6"	4"	B
			14'	S R 4 - 14 34						35'-7"	16'-11 5/8"	34'-9"	35'-7"	5"	C
	63'	TR-34-63-600	10'	S R 4 - 10 34	21	36"	114'	1'-11 3/8"	12"	35'-6"	12'-11 5/8"	34'-8"	35'-6"	4"	B
			12'	S R 4 - 12 34						35'-6"	14'-11 5/8"	34'-8"	35'-6"	4"	B
14'			S R 4 - 14 34	35'-7"						16'-11 5/8"	34'-9"	35'-7"	5"	C	
83'	TR-34-83-600	10'	S R 5 - 10 34	24	54"	136'	1'-11 3/8"	12"	35'-6"	12'-11 5/8"	34'-8"	35'-6"	4"	B	
		12'	S R 5 - 12 34						35'-6"	14'-11 5/8"	34'-8"	35'-6"	4"	B	
		14'	S R 5 - 14 34						35'-7"	16'-11 5/8"	34'-9"	35'-7"	5"	C	
103'	TR-34-103-600	10'	S R 6 - 10 34	28	54"	158'	1'-11 3/8"	12"	35'-6"	12'-11 5/8"	34'-8"	35'-6"	4"	B	
		12'	S R 6 - 12 34						35'-6"	14'-11 5/8"	34'-8"	35'-6"	4"	B	
		14'	S R 6 - 14 34						35'-7"	16'-11 5/8"	34'-9"	35'-7"	5"	C	

20' - 0" MAXIMUM SUPPORT CENTERS

1,000 LB. CAPACITY

23' - 28' - 34' BRIDGE LENGTH

20' - 0" MAXIMUM SUPPORT CENTERS

1,000



BRIDGE CRANE KITS & STAND ALONE KITS

TR SERIES - FREE STANDING TRUSSED RUNWAY BRIDGE CRANE SYSTEMS

BL	RUNWAY LENGTH	BRIDGE & RUNWAY KIT NUMBER	TCH	SUPPORT KIT NUMBER	FESTOON DATA			DIMENSIONAL DATA							
					TROLLEY QTY	FTE	FCL	BRH	HEADER SIZE	HL	OAH	C/C	OAW	COL. SIZE	BASE DETAIL
10'	11.5'	TR - 10 - 11.5 - 700	10' 12' 14'	S G 2 - 10 10 S G 2 - 12 10 S G 2 - 14 10	5	12"	30'	1'-10 1/8"	8"	11'-7"	12'-6 1/8" 14'-6 1/8" 16'-6 1/8"	10'-9"	11'-7"	5"	C
	23'	TR - 10 - 23 - 700	10' 12' 14'	S G 2 - 10 10 S G 2 - 12 10 S G 2 - 14 10	6	12"	43'	1'-10 1/8"	8"	11'-7"	12'-6 1/8" 14'-6 1/8" 16'-6 1/8"	10'-9"	11'-7"	5"	C
	33'	TR - 10 - 33 - 700	10' 12' 14'	S G 3 - 10 10 S G 3 - 12 10 S G 3 - 14 10	8	24"	54'	1'-10 1/8"	8"	11'-7"	12'-6 1/8" 14'-6 1/8" 16'-6 1/8"	10'-9"	11'-7"	5"	C
	43'	TR - 10 - 43 - 700	10' 12' 14'	S G 3 - 10 10 S G 3 - 12 10 S G 3 - 14 10	10	24"	64'	1'-10 1/8"	8"	11'-7"	12'-6 1/8" 14'-6 1/8" 16'-6 1/8"	10'-9"	11'-7"	5"	C
	53'	TR - 10 - 53 - 700	10' 12' 14'	S G 4 - 10 10 S G 4 - 12 10 S G 4 - 14 10	11	36"	76'	1'-10 1/8"	8"	11'-7"	12'-6 1/8" 14'-6 1/8" 16'-6 1/8"	10'-9"	11'-7"	5"	C
	63'	TR - 10 - 63 - 700	10' 12' 14'	S G 4 - 10 10 S G 4 - 12 10 S G 4 - 14 10	13	36"	87'	1'-10 1/8"	8"	11'-7"	12'-6 1/8" 14'-6 1/8" 16'-6 1/8"	10'-9"	11'-7"	5"	C
	83'	TR - 10 - 83 - 700	10' 12' 14'	S G 5 - 10 10 S G 5 - 12 10 S G 5 - 14 10	16	54"	109'	1'-10 1/8"	8"	11'-7"	12'-6 1/8" 14'-6 1/8" 16'-6 1/8"	10'-9"	11'-7"	5"	C
	103'	TR - 10 - 103 - 700	10' 12' 14'	S G 6 - 10 10 S G 6 - 12 10 S G 6 - 14 10	20	54"	131'	1'-10 1/8"	8"	11'-7"	12'-6 1/8" 14'-6 1/8" 16'-6 1/8"	10'-9"	11'-7"	5"	C
15'	23'	TR - 15 - 23 - 700	10' 12' 14'	S H 2 - 10 15 S H 2 - 12 15 S H 2 - 14 15	7	12"	49'	1'-10 1/8"	10"	16'-7"	12'-8 3/8" 14'-8 3/8" 16'-8 3/8"	15'-9"	16'-7"	5"	C
	33'	TR - 15 - 33 - 700	10' 12' 14'	S H 3 - 10 15 S H 3 - 12 15 S H 3 - 14 15	9	24"	60'	1'-10 1/8"	10"	16'-7"	12'-8 3/8" 14'-8 3/8" 16'-8 3/8"	15'-9"	16'-7"	5"	C
	43'	TR - 15 - 43 - 700	10' 12' 14'	S H 3 - 10 15 S H 3 - 12 15 S H 3 - 14 15	11	24"	70'	1'-10 1/8"	10"	16'-7"	12'-8 3/8" 14'-8 3/8" 16'-8 3/8"	15'-9"	16'-7"	5"	C
	53'	TR - 15 - 53 - 700	10' 12' 14'	S H 4 - 10 15 S H 4 - 12 15 S H 4 - 14 15	12	36"	82'	1'-10 1/8"	10"	16'-7"	12'-8 3/8" 14'-8 3/8" 16'-8 3/8"	15'-9"	16'-7"	5"	C
	63'	TR - 15 - 63 - 700	10' 12' 14'	S H 4 - 10 15 S H 4 - 12 15 S H 4 - 14 15	14	36"	93'	1'-10 1/8"	10"	16'-7"	12'-8 3/8" 14'-8 3/8" 16'-8 3/8"	15'-9"	16'-7"	5"	C
	83'	TR - 15 - 83 - 700	10' 12' 14'	S H 5 - 10 15 S H 5 - 12 15 S H 5 - 14 15	17	54"	115'	1'-10 1/8"	10"	16'-7"	12'-8 3/8" 14'-8 3/8" 16'-8 3/8"	15'-9"	16'-7"	5"	C
	103'	TR - 15 - 103 - 700	10' 12' 14'	S H 6 - 10 15 S H 6 - 12 15 S H 6 - 14 15	21	54"	137'	1'-10 1/8"	10"	16'-7"	12'-8 3/8" 14'-8 3/8" 16'-8 3/8"	15'-9"	16'-7"	5"	C
20'	23'	TR - 20 - 23 - 700	10' 12' 14'	S H 2 - 10 20 S H 2 - 12 20 S H 2 - 14 20	9	12"	54'	1'-10 1/8"	10"	21'-7"	12'-8 3/8" 14'-8 3/8" 16'-8 3/8"	20'-9"	21'-7"	5"	C
	33'	TR - 20 - 33 - 700	10' 12' 14'	S H 3 - 10 20 S H 3 - 12 20 S H 3 - 14 20	11	24"	65'	1'-10 1/8"	10"	21'-7"	12'-8 3/8" 14'-8 3/8" 16'-8 3/8"	20'-9"	21'-7"	5"	C
	43'	TR - 20 - 43 - 700	10' 12' 14'	S H 3 - 10 20 S H 3 - 12 20 S H 3 - 14 20	13	24"	75'	1'-10 1/8"	10"	21'-7"	12'-8 3/8" 14'-8 3/8" 16'-8 3/8"	20'-9"	21'-7"	5"	C
	53'	TR - 20 - 53 - 700	10' 12' 14'	S H 4 - 10 20 S H 4 - 12 20 S H 4 - 14 20	14	36"	87'	1'-10 1/8"	10"	21'-7"	12'-8 3/8" 14'-8 3/8" 16'-8 3/8"	20'-9"	21'-7"	5"	C
	63'	TR - 20 - 63 - 700	10' 12' 14'	S H 4 - 10 20 S H 4 - 12 20 S H 4 - 14 20	16	36"	98'	1'-10 1/8"	10"	21'-7"	12'-8 3/8" 14'-8 3/8" 16'-8 3/8"	20'-9"	21'-7"	5"	C
	83'	TR - 20 - 83 - 700	10' 12' 14'	S H 5 - 10 20 S H 5 - 12 20 S H 5 - 14 20	19	54"	120'	1'-10 1/8"	10"	21'-7"	12'-8 3/8" 14'-8 3/8" 16'-8 3/8"	20'-9"	21'-7"	5"	C
	103'	TR - 20 - 103 - 700	10' 12' 14'	S H 6 - 10 20 S H 6 - 12 20 S H 6 - 14 20	23	54"	142'	1'-10 1/8"	10"	21'-7"	12'-8 3/8" 14'-8 3/8" 16'-8 3/8"	20'-9"	21'-7"	5"	C

20' - 0" MAXIMUM SUPPORT CENTERS

2,000 LB. CAPACITY

10' - 15' - 20' BRIDGE LENGTH



BRIDGE CRANE KITS & STAND ALONE KITS

TR SERIES - FREE STANDING TRUSSED RUNWAY BRIDGE CRANE SYSTEMS

BL	RUNWAY LENGTH	BRIDGE & RUNWAY KIT NUMBER	TCH	SUPPORT KIT NUMBER	FESTOON DATA				DIMENSIONAL DATA						
					TROLLEY QTY	FTE	FCL	BRH	HEADER SIZE	HL	OAH	C/C	OAW	COL. SIZE	BASE DETAIL
23'	23'	TR-23-23-700	10' 12' 14'	S J 2-10 23 S J 2-12 23 S J 2-14 23	10	12"	58'	1'-10 1/8"	10"	24'-7"	12'-8 1/4" 14'-8 1/4" 16'-8 1/4"	23'-9"	24'-7"	5"	C
	33'	TR-23-33-700	10' 12' 14'	S J 3-10 23 S J 3-12 23 S J 3-14 23	12	24"	69'	1'-10 1/8"	10"	24'-7"	12'-8 1/4" 14'-8 1/4" 16'-8 1/4"	23'-9"	24'-7"	5"	C
	43'	TR-23-43-700	10' 12' 14'	S J 3-10 23 S J 3-12 23 S J 3-14 23	14	24"	79'	1'-10 1/8"	10"	24'-7"	12'-8 1/4" 14'-8 1/4" 16'-8 1/4"	23'-9"	24'-7"	5"	C
	53'	TR-23-53-700	10' 12' 14'	S J 4-10 23 S J 4-12 23 S J 4-14 23	15	36"	91'	1'-10 1/8"	10"	24'-7"	12'-8 1/4" 14'-8 1/4" 16'-8 1/4"	23'-9"	24'-7"	5"	C
	63'	TR-23-63-700	10' 12' 14'	S J 4-10 23 S J 4-12 23 S J 4-14 23	17	36"	102'	1'-10 1/8"	10"	24'-7"	12'-8 1/4" 14'-8 1/4" 16'-8 1/4"	23'-9"	24'-7"	5"	C
	83'	TR-23-83-700	10' 12' 14'	S J 5-10 23 S J 5-12 23 S J 5-14 23	20	54"	124'	1'-10 1/8"	10"	24'-7"	12'-8 1/4" 14'-8 1/4" 16'-8 1/4"	23'-9"	24'-7"	5"	C
	103'	TR-23-103-700	10' 12' 14'	S J 6-10 23 S J 6-12 23 S J 6-14 23	24	54"	146'	1'-10 1/8"	10"	24'-7"	12'-8 1/4" 14'-8 1/4" 16'-8 1/4"	23'-9"	24'-7"	5"	C
28'	23'	TR-28-23-700	10' 12' 14'	S S 2-10 28 S S 2-12 28 S S 2-14 28	11	12"	63'	2'-0"	12"	29'-7"	13'-0 1/4" 15'-0 1/4" 17'-0 1/4"	28'-9"	29'-7"	5"	C
	33'	TR-28-33-700	10' 12' 14'	S S 3-10 28 S S 3-12 28 S S 3-14 28	13	24"	74'	2'-0"	12"	29'-7"	13'-0 1/4" 15'-0 1/4" 17'-0 1/4"	28'-9"	29'-7"	5"	C
	43'	TR-28-43-700	10' 12' 14'	S S 3-10 28 S S 3-12 28 S S 3-14 28	15	24"	85'	2'-0"	12"	29'-7"	13'-0 1/4" 15'-0 1/4" 17'-0 1/4"	28'-9"	29'-7"	5"	C
	53'	TR-28-53-700	10' 12' 14'	S S 4-10 28 S S 4-12 28 S S 4-14 28	16	36"	96'	2'-0"	12"	29'-7"	13'-0 1/4" 15'-0 1/4" 17'-0 1/4"	28'-9"	29'-7"	5"	C
	63'	TR-28-63-700	10' 12' 14'	S S 4-10 28 S S 4-12 28 S S 4-14 28	18	36"	107'	2'-0"	12"	29'-7"	13'-0 1/4" 15'-0 1/4" 17'-0 1/4"	28'-9"	29'-7"	5"	C
	83'	TR-28-83-700	10' 12' 14'	S S 5-10 28 S S 5-12 28 S S 5-14 28	21	54"	129'	2'-0"	12"	29'-7"	13'-0 1/4" 15'-0 1/4" 17'-0 1/4"	28'-9"	29'-7"	5"	C
	103'	TR-28-103-700	10' 12' 14'	S S 6-10 28 S S 6-12 28 S S 6-14 28	25	54"	151'	2'-0"	12"	29'-7"	13'-0 1/4" 15'-0 1/4" 17'-0 1/4"	28'-9"	29'-7"	5"	C
34'	23'	TR-34-23-700	10' 12' 14'	S T 2-10 34 S T 2-12 34 S T 2-14 34	14	12"	70'	2'-4"	14"	35'-7"	13'-5 7/8" 15'-5 7/8" 17'-5 7/8"	34'-9"	35'-7"	5"	C
	33'	TR-34-33-700	10' 12' 14'	S T 3-10 34 S T 3-12 34 S T 3-14 34	16	24"	81'	2'-4"	14"	35'-7"	13'-5 7/8" 15'-5 7/8" 17'-5 7/8"	34'-9"	35'-7"	5"	C
	43'	TR-34-43-700	10' 12' 14'	S T 3-10 34 S T 3-12 34 S T 3-14 34	18	24"	91'	2'-4"	14"	35'-7"	13'-5 7/8" 15'-5 7/8" 17'-5 7/8"	34'-9"	35'-7"	5"	C
	53'	TR-34-53-700	10' 12' 14'	S T 4-10 34 S T 4-12 34 S T 4-14 34	19	36"	103'	2'-4"	14"	35'-7"	13'-5 7/8" 15'-5 7/8" 17'-5 7/8"	34'-9"	35'-7"	5"	C
	63'	TR-34-63-700	10' 12' 14'	S T 4-10 34 S T 4-12 34 S T 4-14 34	21	36"	114'	2'-4"	14"	35'-7"	13'-5 7/8" 15'-5 7/8" 17'-5 7/8"	34'-9"	35'-7"	5"	C
	83'	TR-34-83-700	10' 12' 14'	S T 5-10 34 S T 5-12 34 S T 5-14 34	24	54"	136'	2'-4"	14"	35'-7"	13'-5 7/8" 15'-5 7/8" 17'-5 7/8"	34'-9"	35'-7"	5"	C
	103'	TR-34-103-700	10' 12' 14'	S T 6-10 34 S T 6-12 34 S T 6-14 34	28	54"	158'	2'-4"	14"	35'-7"	13'-5 7/8" 15'-5 7/8" 17'-5 7/8"	34'-9"	35'-7"	5"	C

20' - 0" MAXIMUM SUPPORT CENTERS

2,000 LB. CAPACITY

23' - 28' - 34' BRIDGE LENGTH

20' - 0" MAXIMUM SUPPORT CENTERS

2,000



BRIDGE CRANE KITS & STAND ALONE KITS

TR SERIES - FREE STANDING TRUSSED RUNWAY BRIDGE CRANE SYSTEMS

BL	RUNWAY LENGTH	BRIDGE & RUNWAY KIT NUMBER	TCH	SUPPORT KIT NUMBER	FESTOON DATA			DIMENSIONAL DATA							
					TROLLEY QTY	FTE	FCL	BRH	HEADER SIZE	HL	OAH	C/C	OAW	COL. SIZE	BASE DETAIL
10'	28'	TR-10-28-425	10' 12' 14'	S25 A 2 - 10 10 S25 A 2 - 12 10 S25 A 2 - 14 10	7	24"	48'	1'-3 7/8"	6"	10'-10"	11'-9 7/8" 13'-9 7/8" 15'-9 7/8"	10'-7"	11'-3"	3"	A
	53'	TR-10-53-425	10' 12' 14'	S25 A 3 - 10 10 S25 A 3 - 12 10 S25 A 3 - 14 10	11	36"	76'	1'-3 7/8"	6"	10'-10"	11'-9 7/8" 13'-9 7/8" 15'-9 7/8"	10'-7"	11'-3"	3"	A
	78'	TR-10-78-425	10' 12' 14'	S25 A 4 - 10 10 S25 A 4 - 12 10 S25 A 4 - 14 10	15	54"	103'	1'-3 7/8"	6"	10'-10"	11'-9 7/8" 13'-9 7/8" 15'-9 7/8"	10'-7"	11'-3"	3"	A
	103'	TR-10-103-425	10' 12' 14'	S25 A 5 - 10 10 S25 A 5 - 12 10 S25 A 5 - 14 10	20	54"	131'	1'-3 7/8"	6"	10'-10"	11'-9 7/8" 13'-9 7/8" 15'-9 7/8"	10'-7"	11'-3"	3"	A
15'	28'	TR-15-28-425	10' 12' 14'	S25 A 2 - 10 15 S25 A 2 - 12 15 S25 A 2 - 14 15	8	24"	54'	1'-3 7/8"	6"	15'-10"	11'-9 7/8" 13'-9 7/8" 15'-9 7/8"	15'-7"	16'-3"	3"	A
	53'	TR-15-53-425	10' 12' 14'	S25 A 3 - 10 15 S25 A 3 - 12 15 S25 A 3 - 14 15	12	36"	82'	1'-3 7/8"	6"	15'-10"	11'-9 7/8" 13'-9 7/8" 15'-9 7/8"	15'-7"	16'-3"	3"	A
	78'	TR-15-78-425	10' 12' 14'	S25 A 4 - 10 15 S25 A 4 - 12 15 S25 A 4 - 14 15	16	54"	109'	1'-3 7/8"	6"	15'-10"	11'-9 7/8" 13'-9 7/8" 15'-9 7/8"	15'-7"	16'-3"	3"	A
	103'	TR-15-103-425	10' 12' 14'	S25 A 5 - 10 15 S25 A 5 - 12 15 S25 A 5 - 14 15	21	54"	137'	1'-3 7/8"	6"	15'-10"	11'-9 7/8" 13'-9 7/8" 15'-9 7/8"	15'-7"	16'-3"	3"	A
20'	28'	TR-20-28-425	10' 12' 14'	S25 B 2 - 10 20 S25 B 2 - 12 20 S25 B 2 - 14 20	10	24"	59'	1'-3 7/8"	8"	20'-10"	12'-0" 14'-0" 16'-0"	20'-7"	21'-3"	3"	A
	53'	TR-20-53-425	10' 12' 14'	S25 B 3 - 10 20 S25 B 3 - 12 20 S25 B 3 - 14 20	14	36"	87'	1'-3 7/8"	8"	20'-10"	12'-0" 14'-0" 16'-0"	20'-7"	21'-3"	3"	A
	78'	TR-20-78-425	10' 12' 14'	S25 B 4 - 10 20 S25 B 4 - 12 20 S25 B 4 - 14 20	18	54"	114'	1'-3 7/8"	8"	20'-10"	12'-0" 14'-0" 16'-0"	20'-7"	21'-3"	3"	A
	103'	TR-20-103-425	10' 12' 14'	S25 B 5 - 10 20 S25 B 5 - 12 20 S25 B 5 - 14 20	23	54"	142'	1'-3 7/8"	8"	20'-10"	12'-0" 14'-0" 16'-0"	20'-7"	21'-3"	3"	A
23'	28'	TR-23-28-425	10' 12' 14'	S25 B 2 - 10 23 S25 B 2 - 12 23 S25 B 2 - 14 23	11	24"	63'	1'-3 7/8"	8"	23'-10"	12'-0" 14'-0" 16'-0"	23'-7"	24'-3"	3"	A
	53'	TR-23-53-425	10' 12' 14'	S25 B 3 - 10 23 S25 B 3 - 12 23 S25 B 3 - 14 23	15	36"	91'	1'-3 7/8"	8"	23'-10"	12'-0" 14'-0" 16'-0"	23'-7"	24'-3"	3"	A
	78'	TR-23-78-425	10' 12' 14'	S25 B 4 - 10 23 S25 B 4 - 12 23 S25 B 4 - 14 23	19	54"	118'	1'-3 7/8"	8"	23'-10"	12'-0" 14'-0" 16'-0"	23'-7"	24'-3"	3"	A
	103'	TR-23-103-425	10' 12' 14'	S25 B 5 - 10 23 S25 B 5 - 12 23 S25 B 5 - 14 23	24	54"	146'	1'-3 7/8"	8"	23'-10"	12'-0" 14'-0" 16'-0"	23'-7"	24'-3"	3"	A
28'	28'	TR-28-28-425	10' 12' 14'	S25 B 2 - 10 28 S25 B 2 - 12 28 S25 B 2 - 14 28	12	24"	68'	1'-5 13/16"	8"	29'-6"	12'-1 15/16" 14'-1 15/16" 16'-1 15/16"	28'-8"	29'-6"	4"	B
	53'	TR-28-53-425	10' 12' 14'	S25 B 3 - 10 28 S25 B 3 - 12 28 S25 B 3 - 14 28	16	36"	96'	1'-5 13/16"	8"	29'-6"	12'-1 15/16" 14'-1 15/16" 16'-1 15/16"	28'-8"	29'-6"	4"	B
	78'	TR-28-78-425	10' 12' 14'	S25 B 4 - 10 28 S25 B 4 - 12 28 S25 B 4 - 14 28	20	54"	123'	1'-5 13/16"	8"	29'-6"	12'-1 15/16" 14'-1 15/16" 16'-1 15/16"	28'-8"	29'-6"	4"	B
	103'	TR-28-103-425	10' 12' 14'	S25 B 5 - 10 28 S25 B 5 - 12 28 S25 B 5 - 14 28	25	54"	151'	1'-5 13/16"	8"	29'-6"	12'-1 15/16" 14'-1 15/16" 16'-1 15/16"	28'-8"	29'-6"	4"	B

25' - 0" MAXIMUM SUPPORT CENTERS

250 LB. CAPACITY

10' - 15' - 20' - 23' - 28' BRIDGE LENGTH

25' - 0" MAXIMUM SUPPORT CENTERS

250 LB.



BRIDGE CRANE KITS & STAND ALONE KITS

TR SERIES - FREE STANDING TRUSSED RUNWAY BRIDGE CRANE SYSTEMS

BL	RUNWAY LENGTH	BRIDGE & RUNWAY KIT NUMBER	TCH	SUPPORT KIT NUMBER	FESTOON DATA				DIMENSIONAL DATA						
					TROLLEY QTY	FTE	FCL	BRH	HEADER SIZE	HL	OAH	C/C	OAW	COL. SIZE	BASE DETAIL
10'	28'	TR - 10 - 28 - 525	10'	S25 C 2 - 10 10	7	24"	48'	1'-6 13/16"	6"	10'-10"	12'-0 13/16"	10'-7"	11'-3"	3"	A
			12'	S25 C 2 - 12 10						11'-6"	14'-0 13/16"	10'-8"	11'-6"	4"	B
			14'	S25 C 2 - 14 10						11'-6"	16'-0 13/16"	10'-8"	11'-6"	4"	B
	53'	TR - 10 - 53 - 525	10'	S25 C 3 - 10 10	11	36"	76'	1'-6 13/16"	6"	10'-10"	12'-0 13/16"	10'-7"	11'-3"	3"	A
			12'	S25 C 3 - 12 10						11'-6"	14'-0 13/16"	10'-8"	11'-6"	4"	B
			14'	S25 C 3 - 14 10						11'-6"	16'-0 13/16"	10'-8"	11'-6"	4"	B
	78'	TR - 10 - 78 - 525	10'	S25 C 4 - 10 10	15	54"	103'	1'-6 13/16"	6"	10'-10"	12'-0 13/16"	10'-7"	11'-3"	3"	A
			12'	S25 C 4 - 12 10						11'-6"	14'-0 13/16"	10'-8"	11'-6"	4"	B
			14'	S25 C 4 - 14 10						11'-6"	16'-0 13/16"	10'-8"	11'-6"	4"	B
	103'	TR - 10 - 103 - 525	10'	S25 C 5 - 10 10	20	54"	131'	1'-6 13/16"	6"	10'-10"	12'-0 13/16"	10'-8"	11'-3"	3"	A
			12'	S25 C 5 - 12 10						11'-6"	14'-0 13/16"	10'-8"	11'-6"	4"	B
			14'	S25 C 5 - 14 10						11'-6"	16'-0 13/16"	10'-8"	11'-6"	4"	B
15'	28'	TR - 15 - 28 - 525	10'	S25 C 2 - 10 15	8	24"	54'	1'-6 13/16"	6"	15'-10"	12'-0 13/16"	15'-7"	16'-3"	3"	A
			12'	S25 C 2 - 12 15						16'-6"	14'-0 13/16"	15'-8"	16'-6"	4"	B
			14'	S25 C 2 - 14 15						16'-6"	16'-0 13/16"	15'-8"	16'-6"	4"	B
	53'	TR - 15 - 53 - 525	10'	S25 C 3 - 10 15	12	36"	82'	1'-6 13/16"	6"	15'-10"	12'-0 13/16"	15'-7"	16'-3"	3"	A
			12'	S25 C 3 - 12 15						16'-6"	14'-0 13/16"	15'-8"	16'-6"	4"	B
			14'	S25 C 3 - 14 15						16'-6"	16'-0 13/16"	15'-8"	16'-6"	4"	B
	78'	TR - 15 - 78 - 525	10'	S25 C 4 - 10 15	16	54"	109'	1'-6 13/16"	6"	15'-10"	12'-0 13/16"	15'-7"	16'-3"	3"	A
			12'	S25 C 4 - 12 15						16'-6"	14'-0 13/16"	15'-8"	16'-6"	4"	B
			14'	S25 C 4 - 14 15						16'-6"	16'-0 13/16"	15'-8"	16'-6"	4"	B
	103'	TR - 15 - 103 - 525	10'	S25 C 5 - 10 15	21	54"	137'	1'-6 13/16"	6"	15'-10"	12'-0 13/16"	15'-7"	16'-3"	3"	A
			12'	S25 C 5 - 12 15						16'-6"	14'-0 13/16"	15'-8"	16'-6"	4"	B
			14'	S25 C 5 - 14 15						16'-6"	16'-0 13/16"	15'-8"	16'-6"	4"	B
20'	28'	TR - 20 - 28 - 525	10'	S25 D 2 - 10 20	10	24"	59'	1'-6 13/16"	8"	20'-10"	12'-2 15/16"	20'-7"	21'-3"	3"	A
			12'	S25 D 2 - 12 20						21'-6"	14'-2 15/16"	20'-8"	21'-6"	4"	B
			14'	S25 D 2 - 14 20						21'-6"	16'-2 15/16"	20'-8"	21'-6"	4"	B
	53'	TR - 20 - 53 - 525	10'	S25 D 3 - 10 20	14	36"	87'	1'-6 13/16"	8"	20'-10"	12'-2 15/16"	20'-7"	21'-3"	3"	A
			12'	S25 D 3 - 12 20						21'-6"	14'-2 15/16"	20'-8"	21'-6"	4"	B
			14'	S25 D 3 - 14 20						21'-6"	16'-2 15/16"	20'-8"	21'-6"	4"	B
	78'	TR - 20 - 78 - 525	10'	S25 D 4 - 10 20	18	54"	114'	1'-6 13/16"	8"	20'-10"	12'-2 15/16"	20'-7"	21'-3"	3"	A
			12'	S25 D 4 - 12 20						21'-6"	14'-2 15/16"	20'-8"	21'-6"	4"	B
			14'	S25 D 4 - 14 20						21'-6"	16'-2 15/16"	20'-8"	21'-6"	4"	B
	103'	TR - 20 - 103 - 525	10'	S25 D 5 - 10 20	23	54"	142'	1'-6 13/16"	8"	20'-10"	12'-2 15/16"	20'-7"	21'-3"	3"	A
			12'	S25 D 5 - 12 20						21'-6"	14'-2 15/16"	20'-8"	21'-6"	4"	B
			14'	S25 D 5 - 14 20						21'-6"	16'-2 15/16"	20'-8"	21'-6"	4"	B
23'	28'	TR - 23 - 28 - 525	10'	S25 D 2 - 10 23	11	24"	63'	1'-6 13/16"	8"	23'-10"	12'-2 15/16"	23'-7"	24'-3"	3"	A
			12'	S25 D 2 - 12 23						24'-6"	14'-2 15/16"	23'-8"	24'-6"	4"	B
			14'	S25 D 2 - 14 23						24'-6"	16'-2 15/16"	23'-8"	24'-6"	4"	B
	53'	TR - 23 - 53 - 525	10'	S25 D 3 - 10 23	15	36"	91'	1'-6 13/16"	8"	23'-10"	12'-2 15/16"	23'-7"	24'-3"	3"	A
			12'	S25 D 3 - 12 23						24'-6"	14'-2 15/16"	23'-8"	24'-6"	4"	B
			14'	S25 D 3 - 14 23						24'-6"	16'-2 15/16"	23'-8"	24'-6"	4"	B
	78'	TR - 23 - 78 - 525	10'	S25 D 4 - 10 23	19	54"	118'	1'-6 13/16"	8"	23'-10"	12'-2 15/16"	23'-7"	24'-3"	3"	A
			12'	S25 D 4 - 12 23						24'-6"	14'-2 15/16"	23'-8"	24'-6"	4"	B
			14'	S25 D 4 - 14 23						24'-6"	16'-2 15/16"	23'-8"	24'-6"	4"	B
	103'	TR - 23 - 103 - 525	10'	S25 D 5 - 10 23	24	54"	146'	1'-6 13/16"	8"	23'-10"	12'-2 15/16"	23'-7"	24'-3"	3"	A
			12'	S25 D 5 - 12 23						24'-6"	14'-2 15/16"	23'-8"	24'-6"	4"	A
			14'	S25 D 5 - 14 23						24'-6"	16'-2 15/16"	23'-8"	24'-6"	4"	A
28'	28'	TR - 28 - 28 - 525	10'	S25 P 2 - 10 28	12	24"	68'	1'-8 5/8"	10"	29'-6"	12'-6 3/4"	28'-8"	29'-6"	4"	B
			12'	S25 P 2 - 12 28						16'-6 3/4"	14'-6 3/4"	28'-8"	29'-6"	4"	B
			14'	S25 P 2 - 14 28						16'-6 3/4"	16'-6 3/4"	28'-8"	29'-6"	4"	B
	53'	TR - 28 - 53 - 525	10'	S25 P 3 - 10 28	16	36"	96'	1'-8 5/8"	10"	29'-6"	12'-6 3/4"	28'-8"	29'-6"	4"	B
			12'	S25 P 3 - 12 28						16'-6 3/4"	14'-6 3/4"	28'-8"	29'-6"	4"	B
			14'	S25 P 3 - 14 28						16'-6 3/4"	16'-6 3/4"	28'-8"	29'-6"	4"	B
	78'	TR - 28 - 78 - 525	10'	S25 P 4 - 10 28	20	54"	123'	1'-8 5/8"	10"	29'-6"	12'-6 3/4"	28'-8"	29'-6"	4"	B
			12'	S25 P 4 - 12 28						16'-6 3/4"	14'-6 3/4"	28'-8"	29'-6"	4"	B
			14'	S25 P 4 - 14 28						16'-6 3/4"	16'-6 3/4"	28'-8"	29'-6"	4"	B
	103'	TR - 28 - 103 - 525	10'	S25 P 5 - 10 28	25	54"	151'	1'-8 5/8"	10"	29'-6"	12'-6 3/4"	28'-8"	29'-6"	4"	B
			12'	S25 P 5 - 12 28						16'-6 3/4"	14'-6 3/4"	28'-8"	29'-6"	4"	B
			14'	S25 P 5 - 14 28						16'-6 3/4"	16'-6 3/4"	28'-8"	29'-6"	4"	B
34'	28'	TR - 34 - 28 - 525	10'	S25 O 2 - 10 34	15	24"	75'	1'-8 5/8"	10"	35'-6"	12'-6 3/4"	34'-8"	35'-6"	4"	B
			12'	S25 O 2 - 12 34						14'-6 3/4"	14'-6 3/4"	34'-8"	35'-6"	4"	B
			14'	S25 O 2 - 14 34						16'-6 3/4"	16'-6 3/4"	34'-8"	35'-6"	4"	B
	53'	TR - 34 - 53 - 525	10'	S25 O 3 - 10 34	19	36"	103'	1'-8 5/8"	10"	35'-6"	12'-6 3/4"	34'-8"	35'-6"	4"	B
			12'	S25 O 3 - 12 34						14'-6 3/4"	14'-6 3/4"	34'-8"	35'-6"	4"	B
			14'	S25 O 3 - 14 34						16'-6 3/4"	16'-6 3/4"	34'-8"	35'-6"	4"	B
	78'	TR - 34 - 78 - 525	10'	S25 O 4 - 10 34	23	54"	130'	1'-8 5/8"	10"	35'-6"	12'-6 3/4"	34'-8"	35'-6"	4"	B
			12'	S25 O 4 - 12 34						14'-6 3/4"	14'-6 3/4"	34'-8"	35'-6"	4"	B
			14'	S25 O 4 - 14 34						16'-6 3/4"	16'-6 3/4"	34'-8"	35'-6"	4"	B
	103'	TR - 34 - 103 - 525	10'	S25 O 5 - 10 34	28	54"	158'	1'-8 5/8"	10"	35'-6"	12'-6 3/4"	34'-8"	35'-6"	4"	B
			12'	S25 O 5 - 12 34						14'-6 3/4"	14'-6 3/4"	34'-8"	35'-6"	4"	B
			14'	S25 O 5 - 14 34						16'-6 3/4"	16'-6 3/4"	34'-8"	35'-6"	4"	B

25' - 0" MAXIMUM SUPPORT CENTERS

10' - 15' - 20' - 23' - 28' - 34' BRIDGE LENGTH 500 LB. CAPACITY

25' - 0" MAXIMUM SUPPORT CENTERS

500 LB.



BRIDGE CRANE KITS & STAND ALONE KITS

TR SERIES - FREE STANDING TRUSSED RUNWAY BRIDGE CRANE SYSTEMS

BL	RUNWAY LENGTH	BRIDGE & RUNWAY KIT NUMBER	TCH	SUPPORT KIT NUMBER	FESTOON DATA			DIMENSIONAL DATA							
					TROLLEY QTY	FTE	FCL	BRH	HEADER SIZE	HL	OAH	C/C	OAW	COL. SIZE	BASE DETAIL
10'	28'	TR - 10- 28 - 625	10'	S25 E 2 - 10 10	7	24"	48'	1'-9 1/2"	8"	11'-6"	12'-5 1/2"	10'-8"	11'-6"	4"	B
			12'	S25 E 2 - 12 10						11'-6"	14'-5 1/2"	10'-8"	11'-6"	4"	B
			14'	S25 E 2 - 14 10						11'-7"	16'-5 1/2"	10'-9"	11'-7"	5"	C
	53'	TR - 10- 53 - 625	10'	S25 E 3 - 10 10	11	36"	76'	1'-9 1/2"	8"	11'-6"	12'-5 1/2"	10'-8"	11'-6"	4"	B
			12'	S25 E 3 - 12 10						11'-6"	14'-5 1/2"	10'-8"	11'-6"	4"	B
			14'	S25 E 3 - 14 10						11'-7"	16'-5 1/2"	10'-9"	11'-7"	5"	C
	78'	TR - 10- 78 - 625	10'	S25 E 4 - 10 10	15	54"	103'	1'-9 1/2"	8"	11'-6"	12'-5 1/2"	10'-8"	11'-6"	4"	B
			12'	S25 E 4 - 12 10						11'-6"	14'-5 1/2"	10'-8"	11'-6"	4"	B
			14'	S25 E 4 - 14 10						11'-7"	16'-5 1/2"	10'-9"	11'-7"	5"	C
	103'	TR - 10- 103 - 625	10'	S25 E 5 - 10 10	20	54"	131'	1'-9 1/2"	8"	11'-6"	12'-5 1/2"	10'-8"	11'-6"	4"	B
			12'	S25 E 5 - 12 10						11'-6"	14'-5 1/2"	10'-8"	11'-6"	4"	B
			14'	S25 E 5 - 14 10						11'-7"	16'-5 1/2"	10'-9"	11'-7"	5"	C
15'	28'	TR - 15- 28 - 625	10'	S25 E 2 - 10 15	8	24"	54'	1'-9 1/2"	8"	16'-6"	12'-5 1/2"	15'-8"	16'-6"	4"	B
			12'	S25 E 2 - 12 15						16'-6"	14'-5 1/2"	15'-8"	16'-6"	4"	B
			14'	S25 E 2 - 14 15						16'-7"	16'-5 1/2"	15'-9"	16'-7"	5"	C
	53'	TR - 15- 53 - 625	10'	S25 E 3 - 10 15	12	36"	82'	1'-9 1/2"	8"	16'-6"	12'-5 1/2"	15'-8"	16'-6"	4"	B
			12'	S25 E 3 - 12 15						16'-6"	14'-5 1/2"	15'-8"	16'-6"	4"	B
			14'	S25 E 3 - 14 15						16'-7"	16'-5 1/2"	15'-9"	16'-7"	5"	C
	78'	TR - 15- 78 - 625	10'	S25 E 4 - 10 15	16	54"	109'	1'-9 1/2"	8"	16'-6"	12'-5 1/2"	15'-8"	16'-6"	4"	B
			12'	S25 E 4 - 12 15						16'-6"	14'-5 1/2"	15'-8"	16'-6"	4"	B
			14'	S25 E 4 - 14 15						16'-7"	16'-5 1/2"	15'-9"	16'-7"	5"	C
	103'	TR - 15- 103 - 625	10'	S25 E 5 - 10 15	21	54"	137'	1'-9 1/2"	8"	16'-6"	12'-5 1/2"	15'-8"	16'-6"	4"	B
			12'	S25 E 5 - 12 15						16'-6"	14'-5 1/2"	15'-8"	16'-6"	4"	B
			14'	S25 E 5 - 14 15						16'-7"	16'-5 1/2"	15'-9"	16'-7"	5"	C
20'	28'	TR - 20- 28 - 625	10'	S25 F 2 - 10 20	10	24"	59'	1'-9 1/2"	8"	21'-6"	12'-5 5/8"	20'-8"	21'-6"	4"	B
			12'	S25 F 2 - 12 20						21'-6"	14'-5 5/8"	20'-8"	21'-6"	4"	B
			14'	S25 F 2 - 14 20						21'-7"	16'-5 5/8"	20'-9"	21'-7"	5"	C
	53'	TR - 20- 53 - 625	10'	S25 F 3 - 10 20	14	36"	87'	1'-9 1/2"	8"	21'-6"	12'-5 5/8"	20'-8"	21'-6"	4"	B
			12'	S25 F 3 - 12 20						21'-6"	14'-5 5/8"	20'-8"	21'-6"	4"	B
			14'	S25 F 3 - 14 20						21'-7"	16'-5 5/8"	20'-9"	21'-7"	5"	C
	78'	TR - 20- 78 - 625	10'	S25 F 4 - 10 20	18	54"	114'	1'-9 1/2"	8"	21'-6"	12'-5 5/8"	20'-8"	21'-6"	4"	B
			12'	S25 F 4 - 12 20						21'-6"	14'-5 5/8"	20'-8"	21'-6"	4"	B
			14'	S25 F 4 - 14 20						21'-7"	16'-5 5/8"	20'-9"	21'-7"	5"	C
	103'	TR - 20- 103 - 625	10'	S25 F 5 - 10 20	23	54"	142'	1'-9 1/2"	8"	21'-6"	12'-5 5/8"	20'-8"	21'-6"	4"	B
			12'	S25 F 5 - 12 20						21'-6"	14'-5 5/8"	20'-8"	21'-6"	4"	B
			14'	S25 F 5 - 14 20						21'-7"	16'-5 5/8"	20'-9"	21'-7"	5"	C
23'	28'	TR - 23- 28 - 625	10'	S25 F 2 - 10 23	11	24"	63'	1'-9 1/2"	8"	24'-6"	12'-5 5/8"	23'-8"	24'-6"	4"	B
			12'	S25 F 2 - 12 23						24'-6"	14'-5 5/8"	23'-8"	24'-6"	4"	B
			14'	S25 F 2 - 14 23						24'-7"	16'-5 5/8"	23'-9"	24'-7"	5"	C
	53'	TR - 23- 53 - 625	10'	S25 F 3 - 10 23	15	36"	91'	1'-9 1/2"	8"	24'-6"	12'-5 5/8"	23'-8"	24'-6"	4"	B
			12'	S25 F 3 - 12 23						24'-6"	14'-5 5/8"	23'-8"	24'-6"	4"	B
			14'	S25 F 3 - 14 23						24'-7"	16'-5 5/8"	23'-9"	24'-7"	5"	C
	78'	TR - 23- 78 - 625	10'	S25 F 4 - 10 23	19	54"	118'	1'-9 1/2"	8"	24'-6"	12'-5 5/8"	23'-8"	24'-6"	4"	B
			12'	S25 F 4 - 12 23						24'-6"	14'-5 5/8"	23'-8"	24'-6"	4"	B
			14'	S25 F 4 - 14 23						24'-7"	16'-5 5/8"	23'-9"	24'-7"	5"	C
	103'	TR - 23- 103 - 625	10'	S25 F 5 - 10 23	24	54"	146'	1'-9 1/2"	8"	24'-6"	12'-5 5/8"	23'-8"	24'-6"	4"	B
			12'	S25 F 5 - 12 23						24'-6"	14'-5 5/8"	23'-8"	24'-6"	4"	B
			14'	S25 F 5 - 14 23						24'-7"	16'-5 5/8"	23'-9"	24'-7"	5"	C
28'	28'	TR - 28- 28 - 625	10'	S25 Q 2 - 10 28	12	24"	68'	1'-11 3/8"	10"	29'-6"	12'-9 1/2"	28'-8"	29'-6"	4"	B
			12'	S25 Q 2 - 12 28						29'-6"	14'-9 1/2"	28'-8"	29'-6"	4"	B
			14'	S25 Q 2 - 14 28						29'-7"	16'-9 1/2"	28'-9"	29'-7"	5"	C
	53'	TR - 28- 53 - 625	10'	S25 Q 3 - 10 28	16	36"	96'	1'-11 3/8"	10"	29'-6"	12'-9 1/2"	28'-8"	29'-6"	4"	B
			12'	S25 Q 3 - 12 28						29'-6"	14'-9 1/2"	28'-8"	29'-6"	4"	B
			14'	S25 Q 3 - 14 28						29'-7"	16'-9 1/2"	28'-9"	29'-7"	5"	C
	78'	TR - 28- 78 - 625	10'	S25 Q 4 - 10 28	20	54"	123'	1'-11 3/8"	10"	29'-6"	12'-9 1/2"	28'-8"	29'-6"	4"	B
			12'	S25 Q 4 - 12 28						29'-6"	14'-9 1/2"	28'-8"	29'-6"	4"	B
			14'	S25 Q 4 - 14 28						29'-7"	16'-9 1/2"	28'-9"	29'-7"	5"	C
	103'	TR - 28- 103 - 625	10'	S25 Q 5 - 10 28	25	54"	151'	1'-11 3/8"	10"	29'-6"	12'-9 1/2"	28'-8"	29'-6"	4"	B
			12'	S25 Q 5 - 12 28						29'-6"	14'-9 1/2"	28'-8"	29'-6"	4"	B
			14'	S25 Q 5 - 14 28						29'-7"	16'-9 1/2"	28'-9"	29'-7"	5"	C
34'	28'	TR - 34- 28 - 625	10'	S25 R 2 - 10 34	15	24"	75'	1'-11 3/8"	12"	35'-6"	12'-11 5/8"	34'-8"	35'-6"	4"	B
			12'	S25 R 2 - 12 34						35'-6"	14'-11 5/8"	34'-8"	35'-6"	4"	B
			14'	S25 R 2 - 14 34						35'-7"	16'-11 5/8"	34'-9"	35'-7"	5"	C
	53'	TR - 34- 53 - 625	10'	S25 R 3 - 10 34	19	36"	103'	1'-11 3/8"	12"	35'-6"	12'-11 5/8"	34'-8"	35'-6"	4"	B
			12'	S25 R 3 - 12 34						35'-6"	14'-11 5/8"	34'-8"	35'-6"	4"	B
			14'	S25 R 3 - 14 34						35'-7"	16'-11 5/8"	34'-9"	35'-7"	5"	C
	78'	TR - 34- 78 - 625	10'	S25 R 4 - 10 34	23	54"	130'	1'-11 3/8"	12"	35'-6"	12'-11 5/8"	34'-8"	35'-6"	4"	B
			12'	S25 R 4 - 12 34						35'-6"	14'-11 5/8"	34'-8"	35'-6"	4"	B
			14'	S25 R 4 - 14 34						35'-7"	16'-11 5/8"	34'-9"	35'-7"	5"	C
	103'	TR - 34- 103 - 625	10'	S25 R 5 - 10 34	28	54"	158'	1'-11 3/8"	12"	35'-6"	12'-11 5/8"	34'-8"	35'-6"	4"	B
			12'	S25 R 5 - 12 34						35'-6"	14'-11 5/8"	34'-8"	35'-6"	4"	B
			14'	S25 R 5 - 14 34						35'-7"	16'-11 5/8"	34'-9"	35'-7"	5"	C

25' - 0" MAXIMUM SUPPORT CENTERS

1,000 LB. CAPACITY

10' - 15' - 20' - 23' - 28' - 34' BRIDGE LENGTH

25' - 0" MAXIMUM SUPPORT CENTERS

1,000



BRIDGE CRANE KITS & STAND ALONE KITS

TR SERIES - FREE STANDING TRUSSED RUNWAY BRIDGE CRANE SYSTEMS

BL	RUNWAY LENGTH	BRIDGE & RUNWAY KIT NUMBER	TCH	SUPPORT KIT NUMBER	FESTOON DATA				DIMENSIONAL DATA						
					TROLLEY QTY	FTE	FCL	BRH	HEADER SIZE	HL	OAH	C/C	OAW	COL. SIZE	BASE DETAIL
10'	28'	TR -10 - 28 - 725	10' 12' 14'	S25 G 2 - 10 10 S25 G 2 - 12 10 S25 G 2 - 14 10	7	24"	48"	2' -2 1/8"	8"	11'-7"	12'-10 1/8" 14'-10 1/8" 16'-10 1/8"	10'-9"	11'-7"	5"	C
	53'	TR -10 - 53 - 725	10' 12' 14'	S25 G 3 - 10 10 S25 G 3 - 12 10 S25 G 3 - 14 10	11	36"	76"	2' -2 1/8"	8"	11'-7"	12'-10 1/8" 14'-10 1/8" 16'-10 1/8"	10'-9"	11'-7"	5"	C
	78'	TR -10 - 78 - 725	10' 12' 14'	S25 G 4 - 10 10 S25 G 4 - 12 10 S25 G 4 - 14 10	15	54"	103"	2' -2 1/8"	8"	11'-7"	12'-10 1/8" 14'-10 1/8" 16'-10 1/8"	10'-9"	11'-7"	5"	C
	103'	TR -10 -103 - 725	10' 12' 14'	S25 G 5 - 10 10 S25 G 5 - 12 10 S25 G 5 - 14 10	20	54"	131"	2' -2 1/8"	8"	11'-7"	12'-10 1/8" 14'-10 1/8" 16'-10 1/8"	10'-9"	11'-7"	5"	C
15'	28'	TR -15 - 28 - 725	10' 12' 14'	S25 H 2 - 10 15 S25 H 2 - 12 15 S25 H 2 - 14 15	8	24"	54"	2' -2 1/8"	10"	16'-7"	13'-0 3/8" 15'-0 3/8" 17'-0 3/8"	15'-9"	16'-7"	5"	C
	53'	TR -15 - 53 - 725	10' 12' 14'	S25 H 3 - 10 15 S25 H 3 - 12 15 S25 H 3 - 14 15	12	36"	82"	2' -2 1/8"	10"	16'-7"	13'-0 3/8" 15'-0 3/8" 17'-0 3/8"	15'-9"	16'-7"	5"	C
	78'	TR -15 - 78 - 725	10' 12' 14'	S25 H 4 - 10 15 S25 H 4 - 12 15 S25 H 4 - 14 15	16	54"	109"	2' -2 1/8"	10"	16'-7"	13'-0 3/8" 15'-0 3/8" 17'-0 3/8"	15'-9"	16'-7"	5"	C
	103'	TR -15 -103 - 725	10' 12' 14'	S25 H 5 - 10 15 S25 H 5 - 12 15 S25 H 5 - 14 15	21	54"	137"	2' -2 1/8"	10"	16'-7"	13'-0 3/8" 15'-0 3/8" 17'-0 3/8"	15'-9"	16'-7"	5"	C
20'	28'	TR -20 - 28 - 725	10' 12' 14'	S25 H 2 - 10 20 S25 H 2 - 12 20 S25 H 2 - 14 20	10	24"	59"	2' -2 1/8"	10"	21'-7"	13'-0 3/8" 15'-0 3/8" 17'-0 3/8"	20'-9"	21'-7"	5"	C
	53'	TR -20 - 53 - 725	10' 12' 14'	S25 H 3 - 10 20 S25 H 3 - 12 20 S25 H 3 - 14 20	14	36"	87"	2' -2 1/8"	10"	21'-7"	13'-0 3/8" 15'-0 3/8" 17'-0 3/8"	20'-9"	21'-7"	5"	C
	78'	TR -20 - 78 - 725	10' 12' 14'	S25 H 4 - 10 20 S25 H 4 - 12 20 S25 H 4 - 14 20	18	54"	114"	2' -2 1/8"	10"	21'-7"	13'-0 3/8" 15'-0 3/8" 17'-0 3/8"	20'-9"	21'-7"	5"	C
	103'	TR -20 -103 - 725	10' 12' 14'	S25 H 5 - 10 20 S25 H 5 - 12 20 S25 H 5 - 14 20	23	54"	142"	2' -2 1/8"	10"	21'-7"	13'-0 3/8" 15'-0 3/8" 17'-0 3/8"	20'-9"	21'-7"	5"	C
23'	28'	TR -23 - 28 - 725	10' 12' 14'	S25 J 2 - 10 23 S25 J 2 - 12 23 S25 J 2 - 14 23	11	24"	63"	2' -2 1/8"	10"	24'-7"	13'-0 1/4" 15'-0 1/4" 17'-0 1/4"	23'-9"	24'-7"	5"	C
	53'	TR -23 - 53 - 725	10' 12' 14'	S25 J 3 - 10 23 S25 J 3 - 12 23 S25 J 3 - 14 23	15	36"	91"	2' -2 1/8"	10"	24'-7"	13'-0 1/4" 15'-0 1/4" 17'-0 1/4"	23'-9"	24'-7"	5"	C
	78'	TR -23 - 78 - 725	10' 12' 14'	S25 J 4 - 10 23 S25 J 4 - 12 23 S25 J 4 - 14 23	19	54"	118"	2' -2 1/8"	10"	24'-7"	13'-0 1/4" 15'-0 1/4" 17'-0 1/4"	23'-9"	24'-7"	5"	C
	103'	TR -23 -103 - 725	10' 12' 14'	S25 J 5 - 10 23 S25 J 5 - 12 23 S25 J 5 - 14 23	24	54"	146"	2' -2 1/8"	10"	24'-7"	13'-0 1/4" 15'-0 1/4" 17'-0 1/4"	23'-9"	24'-7"	5"	C
28'	28'	TR -28 - 28 - 725	10' 12' 14'	S25 S 2 - 10 28 S25 S 2 - 12 28 S25 S 2 - 14 28	12	24"	68"	2' -4"	12"	29'-7"	13'-4 1/4" 15'-4 1/4" 17'-4 1/4"	28'-9"	29'-7"	5"	C
	53'	TR -28 - 53 - 725	10' 12' 14'	S25 S 3 - 10 28 S25 S 3 - 12 28 S25 S 3 - 14 28	16	36"	96"	2' -4"	12"	29'-7"	13'-4 1/4" 15'-4 1/4" 17'-4 1/4"	28'-9"	29'-7"	5"	C
	78'	TR -28 - 78 - 725	10' 12' 14'	S25 S 4 - 10 28 S25 S 4 - 12 28 S25 S 4 - 14 28	20	54"	123"	2' -4"	12"	29'-7"	13'-4 1/4" 15'-4 1/4" 17'-4 1/4"	28'-9"	29'-7"	5"	C
	103'	TR -28 -103 - 725	10' 12' 14'	S25 S 5 - 10 28 S25 S 5 - 12 28 S25 S 5 - 14 28	25	54"	151"	2' -4"	12"	29'-7"	13'-4 1/4" 15'-4 1/4" 17'-4 1/4"	28'-9"	29'-7"	5"	C
34'	28'	TR -34 - 28 - 725	10' 12' 14'	S25 T 2 - 10 34 S25 T 2 - 12 34 S25 T 2 - 14 34	15	24"	75"	2' -4"	14"	35'-7"	13'-5 7/8" 15'-5 7/8" 17'-5 7/8"	34'-9"	35'-7"	5"	C
	53'	TR -34 - 53 - 725	10' 12' 14'	S25 T 3 - 10 34 S25 T 3 - 12 34 S25 T 3 - 14 34	19	36"	103"	2' -4"	14"	35'-7"	13'-5 7/8" 15'-5 7/8" 17'-5 7/8"	34'-9"	35'-7"	5"	C
	78'	TR -34 - 78 - 725	10' 12' 14'	S25 T 4 - 10 34 S25 T 4 - 12 34 S25 T 4 - 14 34	23	54"	130"	2' -4"	14"	35'-7"	13'-5 7/8" 15'-5 7/8" 17'-5 7/8"	34'-9"	35'-7"	5"	C
	103'	TR -34 -103 - 725	10' 12' 14'	S25 T 5 - 10 34 S25 T 5 - 12 34 S25 T 5 - 14 34	28	54"	158"	2' -4"	14"	35'-7"	13'-5 7/8" 15'-5 7/8" 17'-5 7/8"	34'-9"	35'-7"	5"	C

25' - 0" MAXIMUM SUPPORT CENTERS

10' - 15' - 20' - 23' - 28' - 34' BRIDGE LENGTH 2,000 LB. CAPACITY

25' - 0" MAXIMUM SUPPORT CENTERS

2,000



BRIDGE CRANE KITS & STAND ALONE KITS

TR SERIES - FREE STANDING TRUSSED RUNWAY BRIDGE CRANE SYSTEMS

BL	RUNWAY LENGTH	BRIDGE & RUNWAY KIT NUMBER	TCH	SUPPORT KIT NUMBER	FESTOON DATA			DIMENSIONAL DATA							
					TROLLEY QTY	FTE	FCL	BRH	HEADER SIZE	HL	OAH	C/C	OAW	COL. SIZE	BASE DETAIL
10'	28'	TR - 10 - 28 - 925	10' 12' 14'	S25 K 2 - 10 10 S25 K 2 - 12 10 S25 K 2 - 14 10	7	24"	48'	2'-9 1/8"	8"	12'-0"	13'-5 1/8" 15'-5 1/8" 17'-5 1/8"	10'-11"	12'-0"	7"	B
	53'	TR - 10 - 53 - 925	10' 12' 14'	S25 K 3 - 10 10 S25 K 3 - 12 10 S25 K 3 - 14 10	11	36"	76'	2'-9 1/8"	8"	12'-0"	13'-5 1/8" 15'-5 1/8" 17'-5 1/8"	10'-11"	12'-0"	7"	B
	78'	TR - 10 - 78 - 925	10' 12' 14'	S25 K 4 - 10 10 S25 K 4 - 12 10 S25 K 4 - 14 10	15	54"	103'	2'-9 1/8"	8"	12'-0"	13'-5 1/8" 15'-5 1/8" 17'-5 1/8"	10'-11"	12'-0"	7"	B
	103'	TR - 10 - 103 - 925	10' 12' 14'	S25 K 5 - 10 10 S25 K 5 - 12 10 S25 K 5 - 14 10	20	54"	131'	2'-9 1/8"	8"	12'-0"	13'-5 1/8" 15'-5 1/8" 17'-5 1/8"	10'-11"	12'-0"	7"	B
15'	28'	TR - 15 - 28 - 925	10' 12' 14'	S25 L 2 - 10 15 S25 L 2 - 12 15 S25 L 2 - 14 15	8	24"	54'	2'-9 1/8"	10"	17'-0"	13'-7 3/8" 15'-7 3/8" 17'-7 3/8"	15'-11"	17'-0"	7"	B
	53'	TR - 15 - 53 - 925	10' 12' 14'	S25 L 3 - 10 15 S25 L 3 - 12 15 S25 L 3 - 14 15	12	36"	82'	2'-9 1/8"	10"	17'-0"	13'-7 3/8" 15'-7 3/8" 17'-7 3/8"	15'-11"	17'-0"	7"	B
	78'	TR - 15 - 78 - 925	10' 12' 14'	S25 L 4 - 10 15 S25 L 4 - 12 15 S25 L 4 - 14 15	16	54"	109'	2'-9 1/8"	10"	17'-0"	13'-7 3/8" 15'-7 3/8" 17'-7 3/8"	15'-11"	17'-0"	7"	B
	103'	TR - 15 - 103 - 925	10' 12' 14'	S25 L 5 - 10 15 S25 L 5 - 12 15 S25 L 5 - 14 15	21	54"	137'	2'-9 1/8"	10"	17'-0"	13'-7 3/8" 15'-7 3/8" 17'-7 3/8"	15'-11"	17'-0"	7"	B
20'	28'	TR - 20 - 28 - 925	10' 12' 14'	S25 L 2 - 10 20 S25 L 2 - 12 20 S25 L 2 - 14 20	10	24"	59'	2'-9 1/8"	10"	22'-0"	13'-7 3/8" 15'-7 3/8" 17'-7 3/8"	20'-11"	22'-0"	7"	B
	53'	TR - 20 - 53 - 925	10' 12' 14'	S25 L 3 - 10 20 S25 L 3 - 12 20 S25 L 3 - 14 20	14	36"	87'	2'-9 1/8"	10"	22'-0"	13'-7 3/8" 15'-7 3/8" 17'-7 3/8"	20'-11"	22'-0"	7"	B
	78'	TR - 20 - 78 - 925	10' 12' 14'	S25 L 4 - 10 20 S25 L 4 - 12 20 S25 L 4 - 14 20	18	54"	114'	2'-9 1/8"	10"	22'-0"	13'-7 3/8" 15'-7 3/8" 17'-7 3/8"	20'-11"	22'-0"	7"	B
	103'	TR - 20 - 103 - 925	10' 12' 14'	S25 L 5 - 10 20 S25 L 5 - 12 20 S25 L 5 - 14 20	23	54"	142'	2'-9 1/8"	10"	22'-0"	13'-7 3/8" 15'-7 3/8" 17'-7 3/8"	20'-11"	22'-0"	7"	B
23'	28'	TR - 23 - 28 - 925	10' 12' 14'	S25 M 2 - 10 23 S25 M 2 - 12 23 S25 M 2 - 14 23	11	24"	63'	2'-9 1/8"	10"	25'-0"	13'-7 1/4" 15'-7 1/4" 17'-7 1/4"	23'-11"	25'-0"	7"	B
	53'	TR - 23 - 53 - 925	10' 12' 14'	S25 M 3 - 10 23 S25 M 3 - 12 23 S25 M 3 - 14 23	15	36"	91'	2'-9 1/8"	10"	25'-0"	13'-7 1/4" 15'-7 1/4" 17'-7 1/4"	23'-11"	25'-0"	7"	B
	78'	TR - 23 - 78 - 925	10' 12' 14'	S25 M 4 - 10 23 S25 M 4 - 12 23 S25 M 4 - 14 23	19	54"	118'	2'-9 1/8"	10"	25'-0"	13'-7 1/4" 15'-7 1/4" 17'-7 1/4"	23'-11"	25'-0"	7"	B
	103'	TR - 23 - 103 - 925	10' 12' 14'	S25 M 5 - 10 23 S25 M 5 - 12 23 S25 M 5 - 14 23	24	54"	146'	2'-9 1/8"	10"	25'-0"	13'-7 1/4" 15'-7 1/4" 17'-7 1/4"	23'-11"	25'-0"	7"	B
28'	28'	TR - 28 - 28 - 925	10' 12' 14'	S25 U 2 - 10 28 S25 U 2 - 12 28 S25 U 2 - 14 28	12	24"	68'	2'-9 1/8"	14"	30'-0"	13'-11" 15'-11" 17'-11"	28'-11"	30'-0"	7"	B
	53'	TR - 28 - 53 - 925	10' 12' 14'	S25 U 3 - 10 28 S25 U 3 - 12 28 S25 U 3 - 14 28	16	36"	96'	2'-9 1/8"	14"	30'-0"	13'-11" 15'-11" 17'-11"	28'-11"	30'-0"	7"	B
	78'	TR - 28 - 78 - 925	10' 12' 14'	S25 U 4 - 10 28 S25 U 4 - 12 28 S25 U 4 - 14 28	20	54"	123'	2'-9 1/8"	14"	30'-0"	13'-11" 15'-11" 17'-11"	28'-11"	30'-0"	7"	B
	103'	TR - 28 - 103 - 925	10' 12' 14'	S25 U 5 - 10 28 S25 U 5 - 12 28 S25 U 5 - 14 28	25	54"	151'	2'-9 1/8"	14"	30'-0"	13'-11" 15'-11" 17'-11"	28'-11"	30'-0"	7"	B

25' - 0" MAXIMUM SUPPORT CENTERS

4,000 LB. CAPACITY

10' - 15' - 20' - 23' - 28' BRIDGE LENGTH



BRIDGE CRANE KITS & STAND ALONE KITS

TR SERIES - FREE STANDING TRUSSED RUNWAY BRIDGE CRANE SYSTEMS

BL	RUNWAY LENGTH	BRIDGE & RUNWAY KIT NUMBER	TCH	SUPPORT KIT NUMBER	FESTOON DATA			DIMENSIONAL DATA							
					TROLLEY QTY	FTE	FCL	BRH	HEADER SIZE	HL	OAH	C/C	OAW	COL SIZE	BASE DETAIL
10'	34'	TR - 10 - 34 - 530	10'	S30 C 2 - 10 10	8	24"	55'	1'-8 15/16"	6"	10'-10"	12'-2 15/16"	10'-7"	11'-3"	3"	A
			12'	S30 C 2 - 12 10						11'-6"	14'-2 15/16"	10'-8"	11'-6"	4"	B
			14'	S30 C 2 - 14 10						11'-6"	16'-2 15/16"	10'-8"	11'-6"	4"	B
	64'	TR - 10 - 64 - 530	10'	S30 C 3 - 10 10	13	36"	88'	1'-8 15/16"	6"	10'-10"	12'-2 15/16"	10'-7"	11'-3"	3"	A
			12'	S30 C 3 - 12 10						11'-6"	14'-2 15/16"	10'-8"	11'-6"	4"	B
			14'	S30 C 3 - 14 10						11'-6"	16'-2 15/16"	10'-8"	11'-6"	4"	B
	94'	TR - 10 - 94 - 530	10'	S30 C 4 - 10 10	18	54"	121'	1'-8 15/16"	6"	10'-10"	12'-2 15/16"	10'-7"	11'-3"	3"	A
			12'	S30 C 4 - 12 10						11'-6"	14'-2 15/16"	10'-8"	11'-6"	4"	B
			14'	S30 C 4 - 14 10						11'-6"	16'-2 15/16"	10'-8"	11'-6"	4"	B
	124'	TR - 10 - 124 - 530	10'	S30 C 5 - 10 10	23	70"	154'	1'-8 15/16"	6"	10'-10"	12'-2 15/16"	10'-8"	11'-3"	3"	A
			12'	S30 C 5 - 12 10						11'-6"	14'-2 15/16"	10'-8"	11'-6"	4"	B
			14'	S30 C 5 - 14 10						11'-6"	16'-2 15/16"	10'-8"	11'-6"	4"	B
15'	34'	TR - 15 - 34 - 530	10'	S30 C 2 - 10 15	9	24"	60'	1'-8 15/16"	6"	15'-10"	12'-2 15/16"	15'-7"	16'-3"	3"	A
			12'	S30 C 2 - 12 15						16'-6"	14'-2 15/16"	15'-8"	16'-6"	4"	B
			14'	S30 C 2 - 14 15						16'-6"	16'-2 15/16"	15'-8"	16'-6"	4"	B
	64'	TR - 15 - 64 - 530	10'	S30 C 3 - 10 15	14	36"	93'	1'-8 15/16"	6"	15'-10"	12'-2 15/16"	15'-7"	16'-3"	3"	A
			12'	S30 C 3 - 12 15						16'-6"	14'-2 15/16"	15'-8"	16'-6"	4"	B
			14'	S30 C 3 - 14 15						16'-6"	16'-2 15/16"	15'-8"	16'-6"	4"	B
	94'	TR - 15 - 94 - 530	10'	S30 C 4 - 10 15	19	54"	126'	1'-8 15/16"	6"	15'-10"	12'-2 15/16"	15'-7"	16'-3"	3"	A
			12'	S30 C 4 - 12 15						16'-6"	14'-2 15/16"	15'-8"	16'-6"	4"	B
			14'	S30 C 4 - 14 15						16'-6"	16'-2 15/16"	15'-8"	16'-6"	4"	B
	124'	TR - 15 - 124 - 530	10'	S30 C 5 - 10 15	24	70"	159'	1'-8 15/16"	6"	15'-10"	12'-2 15/16"	15'-7"	16'-3"	3"	A
			12'	S30 C 5 - 12 15						16'-6"	14'-2 15/16"	15'-8"	16'-6"	4"	B
			14'	S30 C 5 - 14 15						16'-6"	16'-2 15/16"	15'-8"	16'-6"	4"	B
20'	34'	TR - 20 - 34 - 530	10'	S30 D 2 - 10 20	11	24"	66'	1'-8 15/16"	8"	20'-10"	12'-5 1/16"	20'-7"	21'-3"	3"	A
			12'	S30 D 2 - 12 20						21'-6"	14'-5 1/16"	20'-8"	21'-6"	4"	B
			14'	S30 D 2 - 14 20						21'-6"	16'-5 1/16"	20'-8"	21'-6"	4"	B
	64'	TR - 20 - 64 - 530	10'	S30 D 3 - 10 20	16	36"	99'	1'-8 15/16"	8"	20'-10"	12'-5 1/16"	20'-7"	21'-3"	3"	A
			12'	S30 D 3 - 12 20						21'-6"	14'-5 1/16"	20'-8"	21'-6"	4"	B
			14'	S30 D 3 - 14 20						21'-6"	16'-5 1/16"	20'-8"	21'-6"	4"	B
	94'	TR - 20 - 94 - 530	10'	S30 D 4 - 10 20	21	54"	132'	1'-8 15/16"	8"	20'-10"	12'-5 1/16"	20'-7"	21'-3"	3"	A
			12'	S30 D 4 - 12 20						21'-6"	14'-5 1/16"	20'-8"	21'-6"	4"	B
			14'	S30 D 4 - 14 20						21'-6"	16'-5 1/16"	20'-8"	21'-6"	4"	B
	124'	TR - 20 - 124 - 530	10'	S30 D 5 - 10 20	26	70"	165'	1'-8 15/16"	8"	20'-10"	12'-5 1/16"	20'-7"	21'-3"	3"	A
			12'	S30 D 5 - 12 20						21'-6"	14'-5 1/16"	20'-8"	21'-6"	4"	B
			14'	S30 D 5 - 14 20						21'-6"	16'-5 1/16"	20'-8"	21'-6"	4"	B
23'	34'	TR - 23 - 34 - 530	10'	S30 D 2 - 10 23	12	24"	69'	1'-8 15/16"	8"	23'-10"	12'-5 1/16"	23'-7"	24'-3"	3"	A
			12'	S30 D 2 - 12 23						24'-6"	14'-5 1/16"	23'-8"	24'-6"	4"	B
			14'	S30 D 2 - 14 23						24'-6"	16'-5 1/16"	23'-8"	24'-6"	4"	B
	64'	TR - 23 - 64 - 530	10'	S30 D 3 - 10 23	17	36"	102'	1'-8 15/16"	8"	23'-10"	12'-5 1/16"	23'-7"	24'-3"	3"	A
			12'	S30 D 3 - 12 23						24'-6"	14'-5 1/16"	23'-8"	24'-6"	4"	B
			14'	S30 D 3 - 14 23						24'-6"	16'-5 1/16"	23'-8"	24'-6"	4"	B
	94'	TR - 23 - 94 - 530	10'	S30 D 4 - 10 23	22	54"	135'	1'-8 15/16"	8"	23'-10"	12'-5 1/16"	23'-7"	24'-3"	3"	A
			12'	S30 D 4 - 12 23						24'-6"	14'-5 1/16"	23'-8"	24'-6"	4"	B
			14'	S30 D 4 - 14 23						24'-6"	16'-5 1/16"	23'-8"	24'-6"	4"	B
	124'	TR - 23 - 124 - 530	10'	S30 D 5 - 10 23	27	70"	168'	1'-8 15/16"	8"	23'-10"	12'-5 1/16"	23'-7"	24'-3"	3"	A
			12'	S30 D 5 - 12 23						24'-6"	14'-5 1/16"	23'-8"	24'-6"	4"	B
			14'	S30 D 5 - 14 23						24'-6"	16'-5 1/16"	23'-8"	24'-6"	4"	B
28'	34'	TR - 28 - 34 - 530	10'	S30 P 2 - 10 28	13	24"	75'	1'-10 3/4"	10"	29'-6"	12'-8 7/8"	28'-8"	29'-6"	4"	B
			12'	S30 P 2 - 12 28						14'-8 7/8"	16'-8 7/8"				
			14'	S30 P 2 - 14 28						16'-8 7/8"					
	64'	TR - 28 - 64 - 530	10'	S30 P 3 - 10 28	18	36"	108'	1'-10 3/4"	10"	29'-6"	12'-8 7/8"	28'-8"	29'-6"	4"	B
			12'	S30 P 3 - 12 28						14'-8 7/8"	16'-8 7/8"				
			14'	S30 P 3 - 14 28						16'-8 7/8"					
	94'	TR - 28 - 94 - 530	10'	S30 P 4 - 10 28	23	54"	141'	1'-10 3/4"	10"	29'-6"	12'-8 7/8"	28'-8"	29'-6"	4"	B
			12'	S30 P 4 - 12 28						14'-8 7/8"	16'-8 7/8"				
			14'	S30 P 4 - 14 28						16'-8 7/8"					
	124'	TR - 28 - 124 - 530	10'	S30 P 5 - 10 28	28	70"	174'	1'-10 3/4"	10"	29'-6"	12'-8 7/8"	28'-8"	29'-6"	4"	B
			12'	S30 P 5 - 12 28						14'-8 7/8"	16'-8 7/8"				
			14'	S30 P 5 - 14 28						16'-8 7/8"					
34'	34'	TR - 34 - 34 - 530	10'	S30 O 2 - 10 34	16	24"	81'	1'-10 3/4"	10"	35'-6"	12'-8 7/8"	34'-8"	35'-6"	4"	B
			12'	S30 O 2 - 12 34						14'-8 7/8"	16'-8 7/8"				
			14'	S30 O 2 - 14 34						16'-8 7/8"					
	64'	TR - 34 - 64 - 530	10'	S30 O 3 - 10 34	21	36"	114'	1'-10 3/4"	10"	35'-6"	12'-8 7/8"	34'-8"	35'-6"	4"	B
			12'	S30 O 3 - 12 34						14'-8 7/8"	16'-8 7/8"				
			14'	S30 O 3 - 14 34						16'-8 7/8"					
	94'	TR - 34 - 94 - 530	10'	S30 O 4 - 10 34	26	54"	147'	1'-10 3/4"	10"	35'-6"	12'-8 7/8"	34'-8"	35'-6"	4"	B
			12'	S30 O 4 - 12 34						14'-8 7/8"	16'-8 7/8"				
			14'	S30 O 4 - 14 34						16'-8 7/8"					
	124'	TR - 34 - 124 - 530	10'	S30 O 5 - 10 34	31	70"	180'	1'-10 3/4"	10"	35'-6"	12'-8 7/8"	34'-8"	35'-6"	4"	B
			12'	S30 O 5 - 12 34						14'-8 7/8"	16'-8 7/8"				
			14'	S30 O 5 - 14 34						16'-8 7/8"					

30' - 0" MAXIMUM SUPPORT CENTERS

10' - 15' - 20' - 23' - 28' - 34' BRIDGE LENGTH 500 LB. CAPACITY

30' - 0" MAXIMUM SUPPORT CENTERS

500 LB.



BRIDGE CRANE KITS & STAND ALONE KITS

TR SERIES - FREE STANDING TRUSSED RUNWAY BRIDGE CRANE SYSTEMS

BL	RUNWAY LENGTH	BRIDGE & RUNWAY KIT NUMBER	TCH	SUPPORT KIT NUMBER	FESTOON DATA			DIMENSIONAL DATA							
					TROLLEY QTY	FTE	FCL	BRH	HEADER SIZE	HL	OAH	C/C	OAW	COL. SIZE	BASE DETAIL
10'	34'	TR - 10 - 34 - 630	10'	S30 E 2 - 10 10	8	24"	55'	2'-0 5/8"	8"	11'-6"	12'-8 5/8"	10'-8"	11'-6"	4"	B
			12'	S30 E 2 - 12 10						11'-6"	14'-8 5/8"	10'-8"	11'-6"	4"	B
			14'	S30 E 2 - 14 10						11'-7"	16'-8 5/8"	10'-9"	11'-7"	5"	C
	64'	TR - 10 - 64 - 630	10'	S30 E 3 - 10 10	13	36"	88'	2'-0 5/8"	8"	11'-6"	12'-8 5/8"	10'-8"	11'-6"	4"	B
			12'	S30 E 3 - 12 10						11'-6"	14'-8 5/8"	10'-8"	11'-6"	4"	B
			14'	S30 E 3 - 14 10						11'-7"	16'-8 5/8"	10'-9"	11'-7"	5"	C
	94'	TR - 10 - 94 - 630	10'	S30 E 4 - 10 10	18	54"	121'	2'-0 5/8"	8"	11'-6"	12'-8 5/8"	10'-8"	11'-6"	4"	B
			12'	S30 E 4 - 12 10						11'-6"	14'-8 5/8"	10'-8"	11'-6"	4"	B
			14'	S30 E 4 - 14 10						11'-7"	16'-8 5/8"	10'-9"	11'-7"	5"	C
	124'	TR - 10 - 124 - 630	10'	S30 E 5 - 10 10	23	70"	154'	2'-0 5/8"	8"	11'-6"	12'-8 5/8"	10'-8"	11'-6"	4"	B
			12'	S30 E 5 - 12 10						11'-6"	14'-8 5/8"	10'-8"	11'-6"	4"	B
			14'	S30 E 5 - 14 10						11'-7"	16'-8 5/8"	10'-9"	11'-7"	5"	C
15'	34'	TR - 15 - 34 - 630	10'	S30 E 2 - 10 15	9	24"	60'	2'-0 5/8"	8"	16'-6"	12'-8 5/8"	15'-8"	16'-6"	4"	B
			12'	S30 E 2 - 12 15						16'-6"	14'-8 5/8"	15'-8"	16'-6"	4"	B
			14'	S30 E 2 - 14 15						16'-7"	16'-8 5/8"	15'-9"	16'-7"	5"	C
	64'	TR - 15 - 64 - 630	10'	S30 E 3 - 10 15	14	36"	93'	2'-0 5/8"	8"	16'-6"	12'-8 5/8"	15'-8"	16'-6"	4"	B
			12'	S30 E 3 - 12 15						16'-6"	14'-8 5/8"	15'-8"	16'-6"	4"	B
			14'	S30 E 3 - 14 15						16'-7"	16'-8 5/8"	15'-9"	16'-7"	5"	C
	94'	TR - 15 - 94 - 630	10'	S30 E 4 - 10 15	19	54"	126'	2'-0 5/8"	8"	16'-6"	12'-8 5/8"	15'-8"	16'-6"	4"	B
			12'	S30 E 4 - 12 15						16'-6"	14'-8 5/8"	15'-8"	16'-6"	4"	B
			14'	S30 E 4 - 14 15						16'-7"	16'-8 5/8"	15'-9"	16'-7"	5"	C
	124'	TR - 15 - 124 - 630	10'	S30 E 5 - 10 15	24	70"	159'	2'-0 5/8"	8"	16'-6"	12'-8 5/8"	15'-8"	16'-6"	4"	B
			12'	S30 E 5 - 12 15						16'-6"	14'-8 5/8"	15'-8"	16'-6"	4"	B
			14'	S30 E 5 - 14 15						16'-7"	16'-8 5/8"	15'-9"	16'-7"	5"	C
20'	34'	TR - 20 - 34 - 630	10'	S30 F 2 - 10 20	11	24"	66'	2'-0 5/8"	8"	21'-6"	12'-8 3/4"	20'-8"	21'-6"	4"	B
			12'	S30 F 2 - 12 20						21'-6"	14'-8 3/4"	20'-8"	21'-6"	4"	B
			14'	S30 F 2 - 14 20						21'-7"	16'-8 3/4"	20'-9"	21'-7"	5"	C
	64'	TR - 20 - 64 - 630	10'	S30 F 3 - 10 20	16	36"	99'	2'-0 5/8"	8"	21'-6"	12'-8 3/4"	20'-8"	21'-6"	4"	B
			12'	S30 F 3 - 12 20						21'-6"	14'-8 3/4"	20'-8"	21'-6"	4"	B
			14'	S30 F 3 - 14 20						21'-7"	16'-8 3/4"	20'-9"	21'-7"	5"	C
	94'	TR - 20 - 94 - 630	10'	S30 F 4 - 10 20	21	54"	132'	2'-0 5/8"	8"	21'-6"	12'-8 3/4"	20'-8"	21'-6"	4"	B
			12'	S30 F 4 - 12 20						21'-6"	14'-8 3/4"	20'-8"	21'-6"	4"	B
			14'	S30 F 4 - 14 20						21'-7"	16'-8 3/4"	20'-9"	21'-7"	5"	C
	124'	TR - 20 - 124 - 630	10'	S30 F 5 - 10 20	26	70"	165'	2'-0 5/8"	8"	21'-6"	12'-8 3/4"	20'-8"	21'-6"	4"	B
			12'	S30 F 5 - 12 20						21'-6"	14'-8 3/4"	20'-8"	21'-6"	4"	B
			14'	S30 F 5 - 14 20						21'-7"	16'-8 3/4"	20'-9"	21'-7"	5"	C
23'	34'	TR - 23 - 34 - 630	10'	S30 F 2 - 10 23	12	24"	69'	2'-0 5/8"	8"	24'-6"	12'-8 3/4"	23'-8"	24'-6"	4"	B
			12'	S30 F 2 - 12 23						24'-6"	14'-8 3/4"	23'-8"	24'-6"	4"	B
			14'	S30 F 2 - 14 23						24'-7"	16'-8 3/4"	23'-9"	24'-7"	5"	C
	64'	TR - 23 - 64 - 630	10'	S30 F 3 - 10 23	17	36"	102'	2'-0 5/8"	8"	24'-6"	12'-8 3/4"	23'-8"	24'-6"	4"	B
			12'	S30 F 3 - 12 23						24'-6"	14'-8 3/4"	23'-8"	24'-6"	4"	B
			14'	S30 F 3 - 14 23						24'-7"	16'-8 3/4"	23'-9"	24'-7"	5"	C
	94'	TR - 23 - 94 - 630	10'	S30 F 4 - 10 23	22	54"	135'	2'-0 5/8"	8"	24'-6"	12'-8 3/4"	23'-8"	24'-6"	4"	B
			12'	S30 F 4 - 12 23						24'-6"	14'-8 3/4"	23'-8"	24'-6"	4"	B
			14'	S30 F 4 - 14 23						24'-7"	16'-8 3/4"	23'-9"	24'-7"	5"	C
	124'	TR - 23 - 124 - 630	10'	S30 F 5 - 10 23	27	70"	168'	2'-0 5/8"	8"	24'-6"	12'-8 3/4"	23'-8"	24'-6"	4"	B
			12'	S30 F 5 - 12 23						24'-6"	14'-8 3/4"	23'-8"	24'-6"	4"	B
			14'	S30 F 5 - 14 23						24'-7"	16'-8 3/4"	23'-9"	24'-7"	5"	C
28'	34'	TR - 28 - 34 - 630	10'	S30 Q 2 - 10 28	13	24"	75'	2'-2 1/2"	10"	29'-6"	13'-0 5/8"	28'-8"	29'-6"	4"	B
			12'	S30 Q 2 - 12 28						29'-6"	15'-0 5/8"	28'-8"	29'-6"	4"	B
			14'	S30 Q 2 - 14 28						29'-7"	17'-0 5/8"	28'-9"	29'-7"	5"	C
	64'	TR - 28 - 64 - 630	10'	S30 Q 3 - 10 28	18	36"	108'	2'-2 1/2"	10"	29'-6"	13'-0 5/8"	28'-8"	29'-6"	4"	B
			12'	S30 Q 3 - 12 28						29'-6"	15'-0 5/8"	28'-8"	29'-6"	4"	B
			14'	S30 Q 3 - 14 28						29'-7"	17'-0 5/8"	28'-9"	29'-7"	5"	C
	94'	TR - 28 - 94 - 630	10'	S30 Q 4 - 10 28	23	54"	141'	2'-2 1/2"	10"	29'-6"	13'-0 5/8"	28'-8"	29'-6"	4"	B
			12'	S30 Q 4 - 12 28						29'-6"	15'-0 5/8"	28'-8"	29'-6"	4"	B
			14'	S30 Q 4 - 14 28						29'-7"	17'-0 5/8"	28'-9"	29'-7"	5"	C
	124'	TR - 28 - 124 - 630	10'	S30 Q 5 - 10 28	28	70"	174'	2'-2 1/2"	10"	29'-6"	13'-0 5/8"	28'-8"	29'-6"	4"	B
			12'	S30 Q 5 - 12 28						29'-6"	15'-0 5/8"	28'-8"	29'-6"	4"	B
			14'	S30 Q 5 - 14 28						29'-7"	17'-0 5/8"	28'-9"	29'-7"	5"	C
34'	34'	TR - 34 - 34 - 630	10'	S30 R 2 - 10 34	16	24"	81'	2'-2 1/2"	12"	35'-6"	13'-2 3/4"	34'-8"	35'-6"	4"	B
			12'	S30 R 2 - 12 34						35'-6"	15'-2 3/4"	34'-8"	35'-6"	4"	B
			14'	S30 R 2 - 14 34						35'-7"	17'-2 3/4"	34'-9"	35'-7"	5"	C
	64'	TR - 34 - 64 - 630	10'	S30 R 3 - 10 34	21	36"	114'	2'-2 1/2"	12"	35'-6"	13'-2 3/4"	34'-8"	35'-6"	4"	B
			12'	S30 R 3 - 12 34						35'-6"	15'-2 3/4"	34'-8"	35'-6"	4"	B
			14'	S30 R 3 - 14 34						35'-7"	17'-2 3/4"	34'-9"	35'-7"	5"	C
	94'	TR - 34 - 94 - 630	10'	S30 R 4 - 10 34	26	54"	147'	2'-2 1/2"	12"	35'-6"	13'-2 3/4"	34'-8"	35'-6"	4"	B
			12'	S30 R 4 - 12 34						35'-6"	15'-2 3/4"	34'-8"	35'-6"	4"	B
			14'	S30 R 4 - 14 34						35'-7"	17'-2 3/4"	34'-9"	35'-7"	5"	C
	124'	TR - 34 - 124 - 630	10'	S30 R 5 - 10 34	31	70"	180'	2'-2 1/2"	12"	35'-6"	13'-2 3/4"	34'-8"	35'-6"	4"	B
			12'	S30 R 5 - 12 34						35'-6"	15'-2 3/4"	34'-8"	35'-6"	4"	B
			14'	S30 R 5 - 14 34						35'-7"	17'-2 3/4"	34'-9"	35'-7"	5"	C

30' - 0" MAXIMUM SUPPORT CENTERS

1,000 LB. CAPACITY

10' - 15' - 20' - 23' - 28' - 34' BRIDGE LENGTH

30' - 0" MAXIMUM SUPPORT CENTERS

1,000



BRIDGE CRANE KITS & STAND ALONE KITS

TR SERIES - FREE STANDING TRUSSED RUNWAY BRIDGE CRANE SYSTEMS

BL	RUNWAY LENGTH	BRIDGE & RUNWAY KIT NUMBER	TCH	SUPPORT KIT NUMBER	FESTOON DATA			DIMENSIONAL DATA							
					TROLLEY QTY	FTE	FCL	BRH	HEADER SIZE	HL	OAH	C/C	OAW	COL. SIZE	BASE DETAIL
10'	34'	TR - 10 - 34 - 730	10' 12' 14'	S30 G 2 - 10 10 S30 G 2 - 12 10 S30 G 2 - 14 10	8	24"	55'	2'-4 1/8"	8"	11'-7"	13'-0 1/8" 15'-0 1/8" 17'-0 1/8"	10'-9"	11'-7"	5"	C
	64'	TR - 10 - 64 - 730	10' 12' 14'	S30 G 3 - 10 10 S30 G 3 - 12 10 S30 G 3 - 14 10	13	36"	88'	2'-4 1/8"	8"	11'-7"	13'-0 1/8" 15'-0 1/8" 17'-0 1/8"	10'-9"	11'-7"	5"	C
	94'	TR - 10 - 94 - 730	10' 12' 14'	S30 G 4 - 10 10 S30 G 4 - 12 10 S30 G 4 - 14 10	18	54"	121'	2'-4 1/8"	8"	11'-7"	13'-0 1/8" 15'-0 1/8" 17'-0 1/8"	10'-9"	11'-7"	5"	C
	124'	TR - 10 - 124 - 730	10' 12' 14'	S30 G 5 - 10 10 S30 G 5 - 12 10 S30 G 5 - 14 10	23	70"	154'	2'-4 1/8"	8"	11'-7"	13'-0 1/8" 15'-0 1/8" 17'-0 1/8"	10'-9"	11'-7"	5"	C
15'	34'	TR - 15 - 34 - 730	10' 12' 14'	S30 H 2 - 10 15 S30 H 2 - 12 15 S30 H 2 - 14 15	9	24"	60'	2'-4 1/8"	10"	16'-7"	13'-2 3/8" 15'-2 3/8" 17'-2 3/8"	15'-9"	16'-7"	5"	C
	64'	TR - 15 - 64 - 730	10' 12' 14'	S30 H 3 - 10 15 S30 H 3 - 12 15 S30 H 3 - 14 15	14	36"	93'	2'-4 1/8"	10"	16'-7"	13'-2 3/8" 15'-2 3/8" 17'-2 3/8"	15'-9"	16'-7"	5"	C
	94'	TR - 15 - 94 - 730	10' 12' 14'	S30 H 4 - 10 15 S30 H 4 - 12 15 S30 H 4 - 14 15	19	54"	126'	2'-4 1/8"	10"	16'-7"	13'-2 3/8" 15'-2 3/8" 17'-2 3/8"	15'-9"	16'-7"	5"	C
	124'	TR - 15 - 124 - 730	10' 12' 14'	S30 H 5 - 10 15 S30 H 5 - 12 15 S30 H 5 - 14 15	24	70"	159'	2'-4 1/8"	10"	16'-7"	13'-2 3/8" 15'-2 3/8" 17'-2 3/8"	15'-9"	16'-7"	5"	C
20'	34'	TR - 20 - 34 - 730	10' 12' 14'	S30 H 2 - 10 20 S30 H 2 - 12 20 S30 H 2 - 14 20	11	24"	66'	2'-4 1/8"	10"	21'-7"	13'-2 3/8" 15'-2 3/8" 17'-2 3/8"	20'-9"	21'-7"	5"	C
	64'	TR - 20 - 64 - 730	10' 12' 14'	S30 H 3 - 10 20 S30 H 3 - 12 20 S30 H 3 - 14 20	16	36"	99'	2'-4 1/8"	10"	21'-7"	13'-2 3/8" 15'-2 3/8" 17'-2 3/8"	20'-9"	21'-7"	5"	C
	94'	TR - 20 - 94 - 730	10' 12' 14'	S30 H 4 - 10 20 S30 H 4 - 12 20 S30 H 4 - 14 20	21	54"	132'	2'-4 1/8"	10"	21'-7"	13'-2 3/8" 15'-2 3/8" 17'-2 3/8"	20'-9"	21'-7"	5"	C
	124'	TR - 20 - 124 - 730	10' 12' 14'	S30 H 5 - 10 20 S30 H 5 - 12 20 S30 H 5 - 14 20	26	70"	165'	2'-4 1/8"	10"	21'-7"	13'-2 3/8" 15'-2 3/8" 17'-2 3/8"	20'-9"	21'-7"	5"	C
23'	34'	TR - 23 - 34 - 730	10' 12' 14'	S30 J 2 - 10 23 S30 J 2 - 12 23 S30 J 2 - 14 23	12	24"	69'	2'-4 1/8"	10"	24'-7"	13'-2 1/4" 15'-2 1/4" 17'-2 1/4"	23'-9"	24'-7"	5"	C
	64'	TR - 23 - 64 - 730	10' 12' 14'	S30 J 3 - 10 23 S30 J 3 - 12 23 S30 J 3 - 14 23	17	36"	102'	2'-4 1/8"	10"	24'-7"	13'-2 1/4" 15'-2 1/4" 17'-2 1/4"	23'-9"	24'-7"	5"	C
	94'	TR - 23 - 94 - 730	10' 12' 14'	S30 J 4 - 10 23 S30 J 4 - 12 23 S30 J 4 - 14 23	22	54"	135'	2'-4 1/8"	10"	24'-7"	13'-2 1/4" 15'-2 1/4" 17'-2 1/4"	23'-9"	24'-7"	5"	C
	124'	TR - 23 - 124 - 730	10' 12' 14'	S30 J 5 - 10 23 S30 J 5 - 12 23 S30 J 5 - 14 23	27	70"	168'	2'-4 1/8"	10"	24'-7"	13'-2 1/4" 15'-2 1/4" 17'-2 1/4"	23'-9"	24'-7"	5"	C
28'	34'	TR - 28 - 34 - 730	10' 12' 14'	S30 S 2 - 10 28 S30 S 2 - 12 28 S30 S 2 - 14 28	13	24"	75'	2'-6"	12"	29'-7"	13'-6 1/4" 15'-6 1/4" 17'-6 1/4"	28'-9"	29'-7"	5"	C
	64'	TR - 28 - 64 - 730	10' 12' 14'	S30 S 3 - 10 28 S30 S 3 - 12 28 S30 S 3 - 14 28	18	36"	108'	2'-6"	12"	29'-7"	13'-6 1/4" 15'-6 1/4" 17'-6 1/4"	28'-9"	29'-7"	5"	C
	94'	TR - 28 - 94 - 730	10' 12' 14'	S30 S 4 - 10 28 S30 S 4 - 12 28 S30 S 4 - 14 28	23	54"	141'	2'-6"	12"	29'-7"	13'-6 1/4" 15'-6 1/4" 17'-6 1/4"	28'-9"	29'-7"	5"	C
	124'	TR - 28 - 124 - 730	10' 12' 14'	S30 S 5 - 10 28 S30 S 5 - 12 28 S30 S 5 - 14 28	28	70"	174'	2'-6"	12"	29'-7"	13'-6 1/4" 15'-6 1/4" 17'-6 1/4"	28'-9"	29'-7"	5"	C
34'	34'	TR - 34 - 34 - 730	10' 12' 14'	S30 T 2 - 10 34 S30 T 2 - 12 34 S30 T 2 - 14 34	16	24"	81'	2'-6"	14"	35'-7"	13'-7 7/8" 15'-7 7/8" 17'-7 7/8"	34'-9"	35'-7"	5"	C
	64'	TR - 34 - 64 - 730	10' 12' 14'	S30 T 3 - 10 34 S30 T 3 - 12 34 S30 T 3 - 14 34	21	36"	114'	2'-6"	14"	35'-7"	13'-7 7/8" 15'-7 7/8" 17'-7 7/8"	34'-9"	35'-7"	5"	C
	94'	TR - 34 - 94 - 730	10' 12' 14'	S30 T 4 - 10 34 S30 T 4 - 12 34 S30 T 4 - 14 34	26	54"	147'	2'-6"	14"	35'-7"	13'-7 7/8" 15'-7 7/8" 17'-7 7/8"	34'-9"	35'-7"	5"	C
	124'	TR - 34 - 124 - 730	10' 12' 14'	S30 T 5 - 10 34 S30 T 5 - 12 34 S30 T 5 - 14 34	31	70"	180'	2'-6"	14"	35'-7"	13'-7 7/8" 15'-7 7/8" 17'-7 7/8"	34'-9"	35'-7"	5"	C

30' - 0" MAXIMUM SUPPORT CENTERS

10' - 15' - 20' - 23' - 28' - 34' BRIDGE LENGTH 2,000 LB. CAPACITY

30' - 0" MAXIMUM SUPPORT CENTERS

2,000

STAND ALONE WORKSTATION BRIDGE CRANES



SPANCO Lifting Solutions...

*Stand alone workstation bridge
crane possibilities are infinite.*

*Call us for a local representative
in your area. 800-869-2080*

STAND ALONE WORKSTATION BRIDGE CRANES

We have the solution for all your material handling needs.



Work Station
Ceiling Mounted
Bridge Cranes

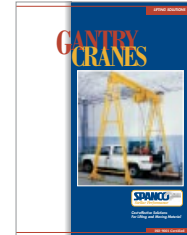

Gantry Cranes



Work Station
Jib Cranes



Jib Cranes



Aluminum
Work Station
Bridge Cranes

*To request the featured literature,
contact your authorized SPANCO
distributor or call SPANCO at the
numbers listed below.*



Morgantown Business Park

604 Hemlock Road

Morgantown, PA 19543 U.S.A.

Tel: (610) 286-7200 Fax: (610) 286-0085

800-869-2080 Canada & U.S.A.

95-800-270-1080 Mexico

Visit SPANCO's Web site: www.spanco.com

