

Gravity Skatewheel Conveyor

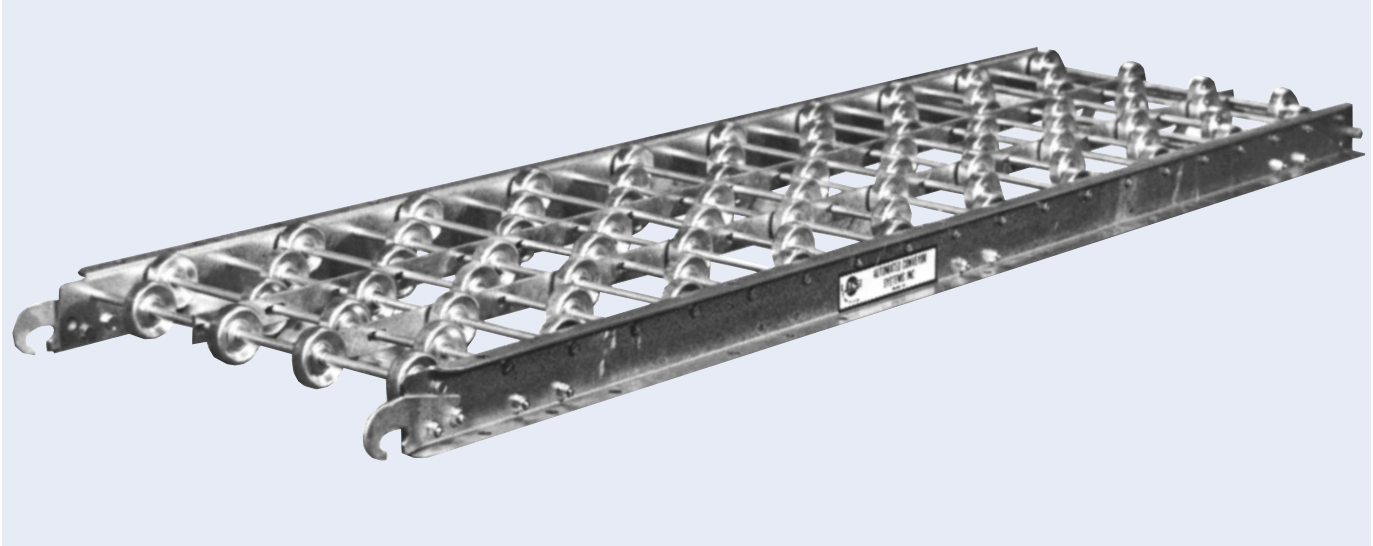

Typical Wheel Patterns

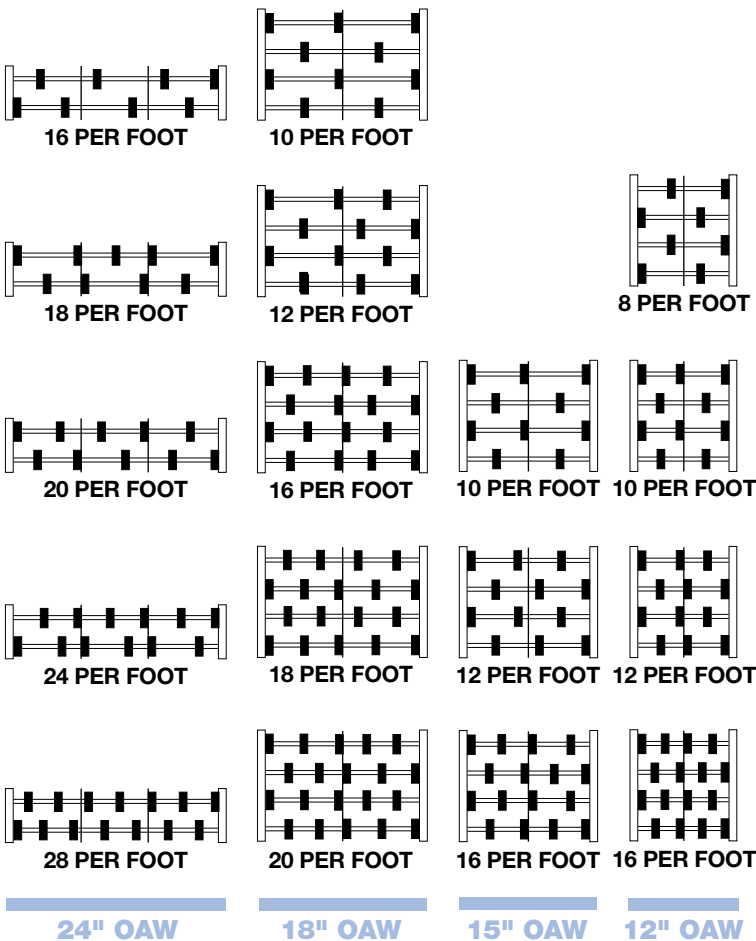

STANDARD SPECIFICATIONS

Frame - Frames are 2½" X 1" x 12 gauge galvanized steel or 2½" x 1" x 1/8" aluminum formed channels. The 12", 15" and 18" wide sections have one 1/8" x 1" axle supports and the 24" wide has two 1/8" x 1" axle supports.

Wheels - Zinc plated steel or aluminum wheels are 1¹⁵/₁₆" diameter x 5/8" face with a steel hardened raceway and a 1³/₁₆" wide cone. Each wheel contains (7) 1/4" hardened and ground steel balls. The lightly oiled baffled construction is designed to keep dirt out.

Cross Braces - 5 ft. long sections have (2) bolted cross members and 10 ft. long sections have (3) bolted cross members.

Axles - All axles are 1/4" diameter cold drawn steel, set on 3" centers and secured with a 1/4" - 20 stop nut.

Wheel Capacity - Steel, 50 lbs; aluminum, 45 lbs.

Wheels Per Foot - Standard patterns include 8, 10, 12, 16, 18, 20, 24 and 28 wheels per foot.

Couplings - Each 5' and 10' section is equipped with a hook and rod connector. The slotted hook permits minor lateral movement. No tools are necessary for assembly, just hook together.

Widths - Standard widths are 12", 15", 18" and 24".

Lengths - Standard lengths are 5' and 10'.

Curves - Standard curves are 45° and 90°. The outside radius is 4 feet. Capacity same as straight sections.

Conveyor Capacity - See Capacity Chart.

Gravity Skatewheel Conveyor



GALVANIZED STEEL STRAIGHT SECTIONS

Model	Wheels Per Foot	Weight	
		10'	5'
12G8-25	8	65	35
12G10-25	10	68	37
12G12-25	12	72	38
12G16-25	16	80	43

Model	Wheels Per Foot	Weight	
		10'	5'
-	-	-	-
15G10-25	10	73	40
15G12-25	12	78	43
15G16-25	16	87	48

Model	Wheels Per Foot	Weight	
		10'	5'
18G10-25	10	72	38
18G12-25	12	77	41
18G16-25	16	87	46
18G18-25	18	92	49
18G20-25	20	98	53

Model	Wheels Per Foot	Weight	
		10'	5'
24G16-25	16	95	52
24G18-25	18	100	55
24G20-25	20	103	57
24G24-25	24	112	62
24G28-25	28	118	65

ALUMINUM STRAIGHT SECTIONS

Model	Wheels Per Foot	Weight	
		10'	5'
12A8-25	8	35	19
12A10-25	10	36	20
12A12-25	12	39	21
12A16-25	16	43	23

Model	Wheels Per Foot	Weight	
		10'	5'
-	-	-	-
15A10-25	10	39	22
15A12-25	12	42	23
15A16-25	16	44	26

Model	Wheels Per Foot	Weight	
		10'	5'
18A10-25	10	40	20
18A12-25	12	41	22
18A16-25	16	46	25
18A18-25	18	49	27
18A20-25	20	52	28

Model	Wheels Per Foot	Weight	
		10'	5'
24A16-25	16	51	28
24A18-25	18	53	29
24A20-25	20	55	30
24A24-25	24	59	32
24A28-25	28	63	34

GALVANIZED STEEL CURVE SECTIONS

Model	Wheels Per Foot	Weight	
		90°	45°
12G90-25	12	72	-
12G45-25	12	-	35

Model	Wheels Per Foot	Weight	
		90°	45°
15G90-25	12	77	-
15G45-25	12	-	40

Model	Wheels Per Foot	Weight	
		90°	45°
18G90-25	18	82	-
18G45-25	18	-	46

Model	Wheels Per Foot	Weight	
		90°	45°
24G90-25	24	112	-
24G45-25	24	-	60

ALUMINUM CURVE SECTIONS

Model	Wheels Per Foot	Weight	
		90°	45°
12A90-25	12	45	-
12A45-25	12	-	23

Model	Wheels Per Foot	Weight	
		90°	45°
15A90-25	12	48	-
15A45-25	12	-	25

Model	Wheels Per Foot	Weight	
		90°	45°
18A90-25	18	51	-
18A45-25	18	-	27

Model	Wheels Per Foot	Weight	
		90°	45°
24A90-25	24	65	-
24A45-25	24	-	34

Frame Capacity Chart

Frame Material	Support Centers	Distributed Live Load Per Foot	Maximum Load Per Wheel
Galvanized Steel	10'	38 lbs.	50 lbs.
	5'	270 lbs.	

NOTE: All capacities are based on distributed loads with a maximum deflection of $\frac{7}{8}$ " over 10'. Section capacities are subject to the total capacity of all wheels in a section but should not exceed above listed frame capacities.

Frame Capacity Chart

Frame Material	Support Centers	Distributed Live Load Per Foot	Maximum Load Per Wheel
Aluminum	10'	18 lbs.	45 lbs.
	5'	150 lbs.	

NOTE: All capacities are based on distributed loads with a maximum deflection of $1\frac{1}{4}$ " over 10'. Section capacities are subject to the total capacity of all wheels in a section but should not exceed above listed frame capacities.

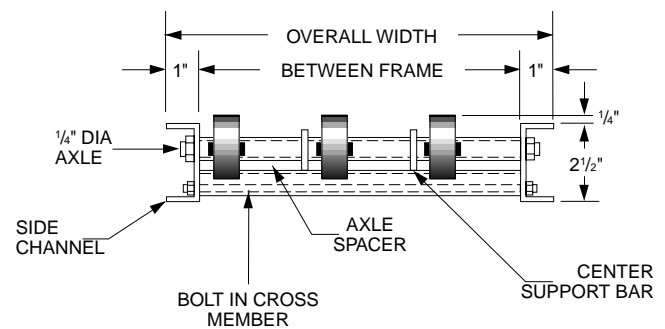
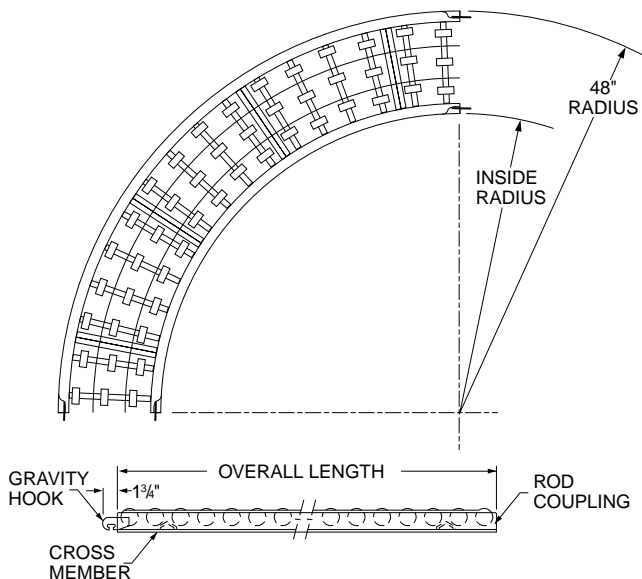

INSIDE RADIUS		OUTSIDE RADIUS	
Overall Width	Inside Radius	Overall Width	Outside Radius
12"	36"	12"	48"
15"	33"	15"	48"
18"	30"	18"	48"
24"	24"	24"	48"

MODELS "138SR, 138AR and 138SRH" Gravity Roller Conveyor

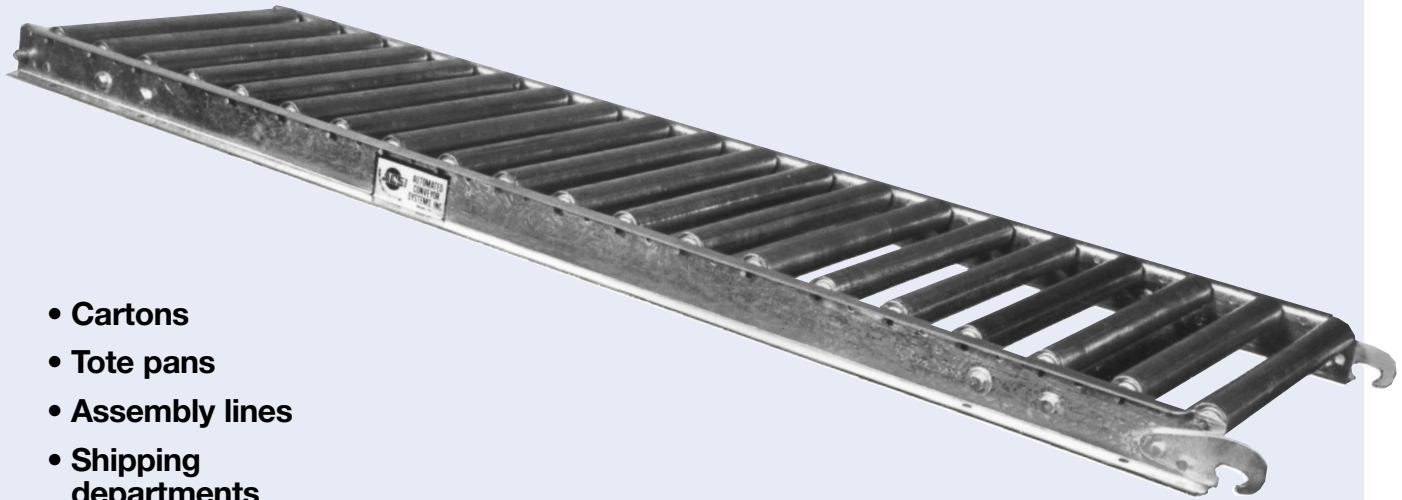

- Cartons
- Tote pans
- Assembly lines
- Shipping departments

Steel, Model 138SR and Model 138SRH

STANDARD SPECIFICATIONS

Frames - 2 1/2" deep x 1" flange x 12 gauge galvanized steel. Rugged cross members bolted between channels.

Rollers - 1 3/8" diameter x 18 gauge galvanized steel tubing with swaged ends for a firm bearing seat. Rollers have spring loaded axle for easy removal or insertion.

Axles - 1/4" diameter cold rolled steel for Model 138SR; 5/16" hex for Model 138SRH.

Couplings - Hook and rod.

Widths - 12", 15", 18" and 24" overall width.

Length - 5' and 10' long straight sections.

Capacity - See Frame Capacity Chart.

Aluminum, Model 138AR

STANDARD SPECIFICATIONS

Frames - 2 1/2" deep x 1" flange x 1/8" heat treated aluminum. Rugged aluminum cross members bolted between channels.

Rollers - 1 3/8" diameter heat treated aluminum tubing with swaged ends for a firm bearing seat. Rollers have spring loaded axle for easy removal or insertion.

Axles - 1/4" diameter cold rolled steel.

Couplings - Hook and rod.

Widths - 12", 15", 18" and 24" overall width.

Length - 5' and 10' long straight sections.

Capacity - See Frame Capacity Chart.

Frame Capacity Chart

Frame Material	Support Centers	Frame Capacity (lbs.) Maximum Distributed Live Load Per Foot	Roller Capacity (lbs.) Maximum Load Per Roller
Galvanized Steel	5'	270	50
	10'	38	
Aluminum	5'	150	35
	10'	18	

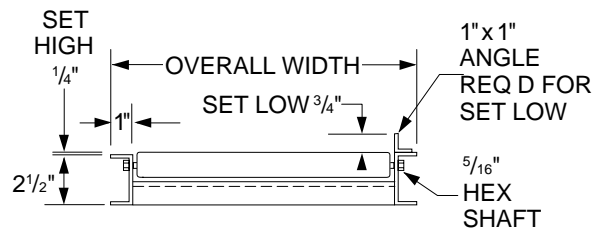

MODELS "138SR, 138AR and 138SRH"



12" OAW				15" OAW				18" OAW				24" OAW			
Model	Roller Centers	Weight		Model	Roller Centers	Weight		Model	Roller Centers	Weight		Model	Roller Centers	Weight	
		10'	5'			10'	5'			10'	5'			10'	5'
ALUMINUM (Model 138AR) STRAIGHT SECTIONS - WEIGHTS															
138AR-12-1½	1½"	53	29	138AR-15-1½	1½"	56	33	138AR-18-1½	1½"	70	38	138AR-24-1½	1½"	88	48
138AR-12-3	3"	36	20	138AR-15-3	3"	41	23	138AR-18-3	3"	51	27	138AR-24-3	3"	56	30
138AR-12-4½	4½"	30	17	138AR-15-4½	4½"	32	18	138AR-18-4½	4½"	38	20	138AR-24-4½	4½"	46	25
138AR-12-6	6"	27	15	138AR-15-6	6"	29	16	138AR-18-6	6"	33	18	138AR-24-6	6"	41	22
138AR-12-9	9"	24	14	138AR-15-9	9"	26	14	138AR-18-9	9"	30	16	138AR-24-9	9"	36	19
138AR-12-12	12"	23	12	138AR-15-12	12"	24	13	138AR-18-12	12"	27	14	138AR-24-12	12"	33	18
STEEL (Model 138SR) STRAIGHT SECTIONS - WEIGHTS															
138SR-12-1½	1½"	101	55	138SR-15-1½	1½"	122	62	138SR-18-1½	1½"	135	72	138SR-24-1½	1½"	168	91
138SR-12-3	3"	68	37	138SR-15-3	3"	78	42	138SR-18-3	3"	97	47	138SR-24-3	3"	108	58
138SR-12-4½	4½"	58	32	138SR-15-4½	4½"	61	33	138SR-18-4½	4½"	73	40	138SR-24-4½	4½"	88	47
138SR-12-6	6"	52	29	138SR-15-6	6"	55	30	138SR-18-6	6"	63	32	138SR-24-6	6"	78	42
138SR-12-9	9"	47	26	138SR-15-9	9"	50	27	138SR-18-9	9"	57	29	138SR-24-9	9"	69	37
138SR-12-12	12"	44	24	138SR-15-12	12"	46	26	138SR-18-12	12"	52	27	138SR-24-12	12"	63	34
STEEL (Model 138SRH) STRAIGHT SECTIONS - WEIGHTS															
138SRH-12-1½	1½"	111	61	138SRH-15-1½	1½"	134	68	138SRH-18-1½	1½"	148	79	138SRH-24-1½	1½"	184	100
138SRH-12-3	3"	75	41	138SRH-15-3	3"	86	46	138SRH-18-3	3"	106	51	138SRH-24-3	3"	118	64
138SRH-12-4½	4½"	64	35	138SRH-15-4½	4½"	67	36	138SRH-18-4½	4½"	80	44	138SRH-24-4½	4½"	97	52
138SRH-12-6	6"	57	32	138SRH-15-6	6"	60	33	138SRH-18-6	6"	69	35	138SRH-24-6	6"	85	46
138SRH-12-9	9"	52	28	138SRH-15-9	9"	55	30	138SRH-18-9	9"	62	32	138SRH-24-9	9"	76	40
138SRH-12-12	12"	48	26	138SRH-15-12	12"	50	28	138SRH-18-12	12"	57	29	138SRH-24-12	12"	69	37

WEIGHTS - CURVE SECTION

12" OAW - 3'0" O/R*			15" OAW - 3'3" O/R*			18" OAW - 3'6" O/R*			24" OAW - 4'0" O/R*		
Model	Weight		Model	Weight		Model	Weight		Model	Weight	
	90°	45°		90°	45°		90°	45°		90°	45°
ALUMINUM (Model 138ARC) CURVED SECTIONS - WEIGHTS											
138ARC-12-90	28	-	138ARC-15-90	31	-	138ARC-18-90	35	-	138ARC-24-90	50	-
138ARC-12-45	-	12	138ARC-15-45	-	17	138ARC-18-45	-	19	138ARC-24-45	-	26
STEEL (Model 138SRC) CURVED SECTIONS - WEIGHTS											
138SRC-12-90	70	-	138SRC-15-90	75	-	138SRC-18-90	80	-	138SRC-24-90	141	-
138SRC-12-45	-	35	138SRC-15-45	-	40	138SRC-18-45	-	45	138SRC-24-45	-	66
STEEL (Model 138SRCH) CURVED SECTIONS - WEIGHTS											
138SRCH-12-90	77	-	138SRCH-15-90	82	-	138SRCH-18-90	88	-	138SRCH-24-90	155	-
138SRCH-12-45	-	38	138SRCH-15-45	-	44	138SRCH-18-45	-	49	138SRCH-24-45	-	72

*Outside radius

RADIUS CHART	
Overall Width	Inside Radius
12"	25"
15"	25"
18"	25"
24"	25"

Note: Double rollers are standard on 24" OAW

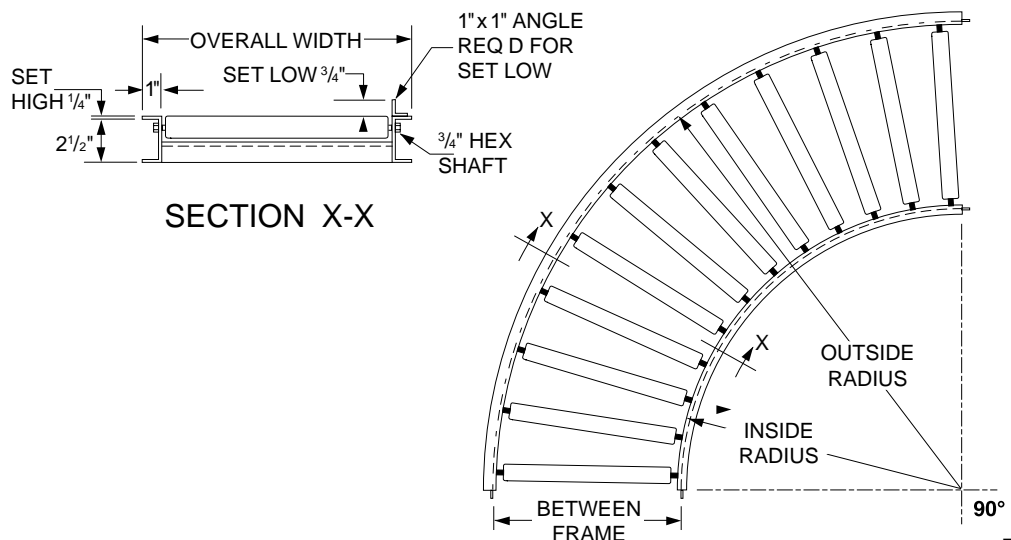

MODELS "190SR, 190SRC, 190HSR and 190HSRC" Gravity Roller Conveyor

STANDARD SPECIFICATIONS

Frames - 3 1/2" deep x 1 1/2" flange x 10 gauge painted steel with bolt-in cross members, rollers set 1/4" high. Galvanized channels optional.

Rollers - 1.9" diameter x 16 gauge steel tubing with swaged ends to provide a firm bearing seat and rounded ends. Galvanized rollers optional. Tapered rollers in curve are 2 1/2" to 1 11/16" taper.

Bearings - Labyrinth sealed, lightly oiled.

Axles - 7/16" hex CRS shaft, spring-loaded.

Couplings - Butt type, for bolting sections together.

Widths - From 13" between frames (B/F) and wider in two inch increments up to 27"; also 31", 33", 37" and 39" between rails.

Lengths - 5' and 10' long straight sections.

Capacity - 240 pounds per roller with 1,350 pounds maximum distributed live load over 10 foot length; 3,100 pounds maximum distributed live load over 5 foot length.

Curve Degree - 45° and 90° with 2'8 1/2" inside radius for widths up to 27" between frames. 4'0" inside radius for 31", 33", 37", and 39" between frames.

CURVED SECTIONS - WEIGHTS

TAPERED ROLLERS ARE UNPLATED (2 1/2" to 1 11/16" taper)

	Nominal Roller Length (Inches)	Width Between Frames (Inches)	Model No. (For 90°)	(Unplated) Model No. (For 90°)	90° Weight (lbs.)	45° Weight (lbs.)
20 Rollers Per Curve	12	13	190SRC-13-90T	190HSRC-13-90T	94	52
	14	15	190SRC-15-90T	190HSRC-15-90T	126	68
	16	17	190SRC-17-90T	190HSRC-17-90T	137	74
	18	19	190SRC-19-90T	190HSRC-19-90T	152	91
	20	21	190SRC-21-90T	190HSRC-21-90T	167	89
	22	23	190SRC-23-90T	190HSRC-23-90T	178	94
32 Rollers Per Curve	24	25	190SRC-25-90T	190HSRC-25-90T	204	107
	26	27	190SRC-27-90T	190HSRC-27-90T	235	120
	30*	31	190SRC-31-90T	190HSRC-31-90T	338	174
	32*	33	190SRC-33-90T	190HSRC-33-90T	349	180
	36*	37	190SRC-37-90T	190HSRC-37-90T	371	191
	38*	39	190SRC-39-90T	190HSRC-39-90T	410	210
STRAIGHT ROLLERS						
Single Rollers 22 Per 90° Curve	12	13	190SRC-13-90S	190HSRC-13-90S	97	50
	14	15	190SRC-15-90S	190HSRC-15-90S	105	53
	16	17	190SRC-17-90S	190HSRC-17-90S	114	58
	18	19	190SRC-19-90S	190HSRC-19-90S	122	63
Double Rollers 42 Per 90° Curve	20	21	190SRC-21-90S	190HSRC-21-90S	131	67
	22	23	190SRC-23-90D	190HSRC-23-90D	161	82
	24	25	190SRC-25-90D	190HSRC-25-90D	169	85
	26	27	190SRC-27-90D	190HSRC-27-90D	177	89
	30*	31	190SRC-31-90D	190HSRC-31-90D	211	108
	32*	33	190SRC-33-90D	190HSRC-33-90D	220	112
	36*	37	190SRC-37-90D	190HSRC-37-90D	238	120
	38*	39	190SRC-39-90D	190HSRC-39-90D	247	124

*4'0" inside radius. All others 2'8 1/2" inside radius.

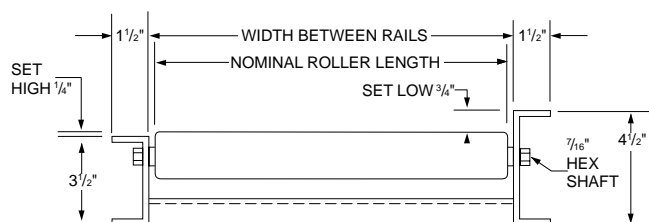

STRAIGHT SECTIONS - WEIGHTS

Nominal Roller Length	Width Between Frames	Model No. Galvanized	Model No. (Unplated)	Roller Centers (Inches)	10' Weight (lbs.)	5' Weight (lbs.)
12"	13"	190SR-13-3	190HSR-13-3	3	167	85
		190SR-13-4 1/2	190HSR-13-4 1/2	4 1/2	137	70
		190SR-13-6	190HSR-13-6	6	119	60
		190SR-13-9	190HSR-13-9	9	104	53
		190SR-13-12	190HSR-13-12	12	94	48
14"	15"	190SR-15-3	190HSR-15-3	3	180	91
		190SR-15-4 1/2	190HSR-15-4 1/2	4 1/2	145	74
		190SR-15-6	190HSR-15-6	6	125	64
		190SR-15-9	190HSR-15-9	9	108	55
		190SR-15-12	190HSR-15-12	12	97	50
16"	17"	190SR-17-3	190HSR-17-3	3	192	97
		190SR-17-4 1/2	190HSR-17-4 1/2	4 1/2	153	78
		190SR-17-6	190HSR-17-6	6	131	66
		190SR-17-9	190HSR-17-9	9	112	57
		190SR-17-12	190HSR-17-12	12	100	51
18"	19"	190SR-19-3	190HSR-19-3	3	204	103
		190SR-19-4 1/2	190HSR-19-4 1/2	4 1/2	161	82
		190SR-19-6	190HSR-19-6	6	137	70
		190SR-19-9	190HSR-19-9	9	117	60
		190SR-19-12	190HSR-19-12	12	103	53
20"	21"	190SR-21-3	190HSR-21-3	3	217	110
		190SR-21-4 1/2	190HSR-21-4 1/2	4 1/2	170	86
		190SR-21-6	190HSR-21-6	6	143	73
		190SR-21-9	190HSR-21-9	9	121	62
		190SR-21-12	190HSR-21-12	12	106	54
22"	23"	190SR-23-3	190HSR-23-3	3	229	116
		190SR-23-4 1/2	190HSR-23-4 1/2	4 1/2	178	90
		190SR-23-6	190HSR-23-6	6	150	76
		190SR-23-9	190HSR-23-9	9	125	64
		190SR-23-12	190HSR-23-12	12	109	56
24"	25"	190SR-25-3	190HSR-25-3	3	241	122
		190SR-25-4 1/2	190HSR-25-4 1/2	4 1/2	186	99
		190SR-25-6	190HSR-25-6	6	156	79
		190SR-25-9	190HSR-25-9	9	129	66
		190SR-25-12	190HSR-25-12	12	112	57
26"	27"	190SR-27-3	190HSR-27-3	3	254	128
		190SR-27-4 1/2	190HSR-27-4 1/2	4 1/2	194	98
		190SR-27-6	190HSR-27-6	6	162	82
		190SR-27-9	190HSR-27-9	9	134	68
		190SR-27-12	190HSR-27-12	12	115	58
30"	31"	190SR-31-3	190HSR-31-3	3	279	141
		190SR-31-4 1/2	190HSR-31-4 1/2	4 1/2	211	107
		190SR-31-6	190HSR-31-6	6	174	88
		190SR-31-9	190HSR-31-9	9	142	72
		190SR-31-12	190HSR-31-12	12	122	62
32"	33"	190SR-33-3	190HSR-33-3	3	291	147
		190SR-33-4 1/2	190HSR-33-4 1/2	4 1/2	180	111
		190SR-33-6	190HSR-33-6	6	147	91
		190SR-33-9	190HSR-33-9	9	125	75
		190SR-33-12	190HSR-33-12	12	128	64
36"	37"	190SR-37-3	190HSR-37-3	3	316	159
		190SR-37-4 1/2	190HSR-37-4 1/2	4 1/2	236	119
		190SR-37-6	190HSR-37-6	6	193	96
		190SR-37-9	190HSR-37-9	9	155	79
		190SR-37-12	190HSR-37-12	12	131	67
38"	39"	190SR-39-3	190HSR-39-3	3	328	165
		190SR-39-4 1/2	190HSR-39-4 1/2	4 1/2	244	123
		190SR-39-6	190HSR-39-6	6	199	101
		190SR-39-9	190HSR-39-9	9	159	81
		190SR-39-12	190HSR-39-12	12	134	68

MODELS "20SR and 20SRC"

Gravity Roller Conveyor



STANDARD SPECIFICATIONS

Frames - 3 1/2" deep x 1 1/2" flange x 10 gauge painted steel with bolt-in cross members, rollers set 1/4" high.

Rollers - 2" diameter x 12 gauge unplated steel tubing with swaged ends to provide a firm bearing seat and rounded ends. Tapered rollers in curve are 2 1/2" to 1 1/16" taper, unplated.

Bearings - Labyrinth sealed, lightly oiled.

Axles - 7/16" hex shaft, spring-loaded.

Couplings - Butt type, for bolting sections together.

Widths - From 13" between frames (B/F) and wider in two inch increments up to 27"; also 31", 33", 37" and 39" between rails.

Lengths - 10' and 5' long straight sections.

Capacity - 300 pounds per roller with 1,350 pounds maximum distributed live load over 10 foot length; 3,100 pounds maximum distributed live load over 5 foot length.

Curve Degree - 45° and 90° with 2'8 1/2" inside radius for widths up to 27" between frames. 4'0" inside radius for 31", 33", 37", and 39" between frames.

CURVED SECTIONS - WEIGHTS

TAPERED ROLLERS					
	Nominal Roller Length (Inches)	Width Between Frames (Inches)	Model No.	90° Weight (lbs.)	45° Weight (lbs.)
20 Rollers Per Curve	12	13	20SRC-13-90T	104	58
	14	15	20SRC-15-90T	115	63
	16	17	20SRC-17-90T	126	68
	18	19	20SRC-19-90T	139	75
	20	21	20SRC-21-90T	171	91
	22	23	20SRC-23-90T	182	96
32 Rollers Per Curve	24	25	20SRC-25-90T	208	109
	26	27	20SRC-27-90T	234	122
	30*	31	20SRC-31-90T	348	179
	32*	33	20SRC-33-90T	359	185
	36*	37	20SRC-37-90T	381	197
	38*	39	20SRC-39-90T	420	215
STRAIGHT ROLLERS					
Single Rollers 22 Per 90° Curve	12	13	20SRC-13-90S	119	61
	14	15	20SRC-15-90S	131	68
	16	17	20SRC-17-90S	144	73
	18	19	20SRC-19-90S	155	80
Double Rollers 42 Per 90° Curve	20	21	20SRC-21-90S	166	84
	22	23	20SRC-23-90D	199	101
	24	25	20SRC-25-90D	211	106
	26	27	20SRC-27-90D	223	112
	30*	31	20SRC-31-90D	262	134
	32*	33	20SRC-33-90D	275	140
	36*	37	20SRC-37-90D	301	152
	38*	39	20SRC-39-90D	314	158

*4'0" inside radius. All others 2'8 1/2" inside radius.

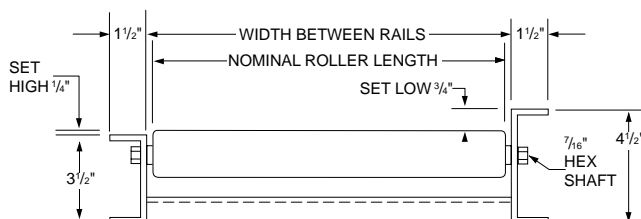

STRAIGHT SECTIONS - WEIGHTS

Nominal Roller Length	Width Between Frames	Model No.	Roller Centers (Inches)	10' Weight (lbs.)	5' Weight (lbs.)
12"	13"	20SR-13-3	3	207	105
		20SR-13-4 1/2	4 1/2	164	84
		20SR-13-6	6	139	70
		20SR-13-9	9	118	60
		20SR-13-12	12	104	53
14"	15"	20SR-15-3	3	227	115
		20SR-15-4 1/2	4 1/2	177	85
		20SR-15-6	6	148	76
		20SR-15-9	9	124	63
		20SR-15-12	12	109	56
16"	17"	20SR-17-3	3	245	124
		20SR-17-4 1/2	4 1/2	189	96
		20SR-17-6	6	158	80
		20SR-17-9	9	131	67
		20SR-17-12	12	113	58
18"	19"	20SR-19-3	3	284	133
		20SR-19-4 1/2	4 1/2	202	103
		20SR-19-6	6	167	85
		20SR-19-9	9	138	71
		20SR-19-12	12	118	61
20"	21"	20SR-21-3	3	284	144
		20SR-21-4 1/2	4 1/2	215	109
		20SR-21-6	6	176	90
		20SR-21-9	9	144	74
		20SR-21-12	12	123	63
22"	23"	20SR-23-3	3	302	153
		20SR-23-4 1/2	4 1/2	227	115
		20SR-23-6	6	187	95
		20SR-23-9	9	151	77
		20SR-23-12	12	127	65
24"	25"	20SR-25-3	3	321	162
		20SR-25-4 1/2	4 1/2	240	126
		20SR-25-6	6	196	99
		20SR-25-9	9	157	80
		20SR-25-12	12	132	67
26"	27"	20SR-27-3	3	341	172
		20SR-27-4 1/2	4 1/2	253	128
		20SR-27-6	6	205	104
		20SR-27-9	9	164	83
		20SR-27-12	12	137	69
30"	31"	20SR-31-3	3	379	191
		20SR-31-4 1/2	4 1/2	279	141
		20SR-31-6	6	224	113
		20SR-31-9	9	117	90
		20SR-31-12	12	147	75
32"	33"	20SR-33-3	3	389	201
		20SR-33-4 1/2	4 1/2	291	147
		20SR-33-6	6	233	118
		20SR-33-9	9	184	94
		20SR-33-12	12	152	78
36"	37"	20SR-37-3	3	436	219
		20SR-37-4 1/2	4 1/2	350	175
		20SR-37-6	6	317	160
		20SR-37-9	9	253	128
		20SR-37-12	12	161	82
38"	39"	20SR-39-3	3	455	229
		20SR-39-4 1/2	4 1/2	330	166
		20SR-39-6	6	262	133
		20SR-39-9	9	203	103
		20SR-39-12	12	166	84

MODEL "GS"

Gravity Skatewheel Spur Conveyor

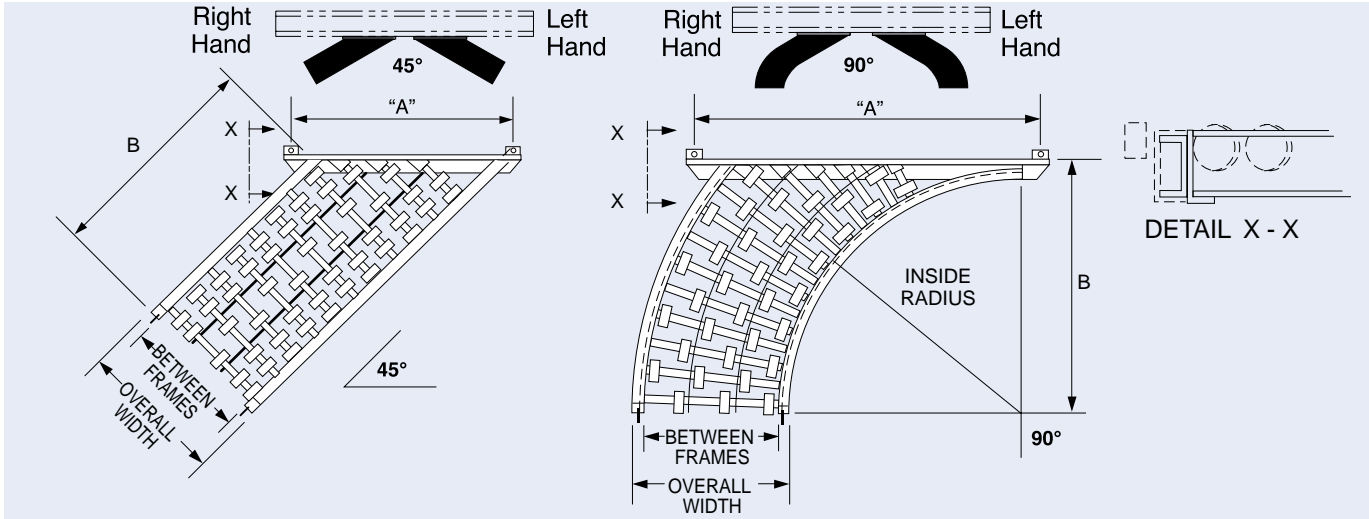

SPECIFICATIONS

Widths - 12", 15", 18" and 24"

Bolt in cross members

Couplings - Bar and hooks on one end

Right and left hand units

Spurs - 45° and 90°

Overall Frame Width	Model No.	45° SPUR					Model No.	90° SPUR				
		"A"	WPF	"B" Weights (lbs.)				"A"	"B"	"R"	WPF	Weights (lbs.)
				2'	3'	5'						
12"	12GS-45-25	21"	16	31	39	56	12GS-90-25	39"	37 1/2"	36"	16	67
15"	15GS-45-25	30"	16	34	43	62	15GS-90-25	39"	34 1/2"	33"	16	72
18"	18GS-45-25	30"	20	38	47	66	18GS-90-25	39"	31 1/2"	30"	20	77
24"	24GS-45-25	39"	28	44	57	83	24GS-90-25	51"	37 1/2"	36"	28	107

NOTE: Same per foot capacities as straight sections shown on page 72.

MODEL "138SRS"

Gravity Roller Spur Conveyor

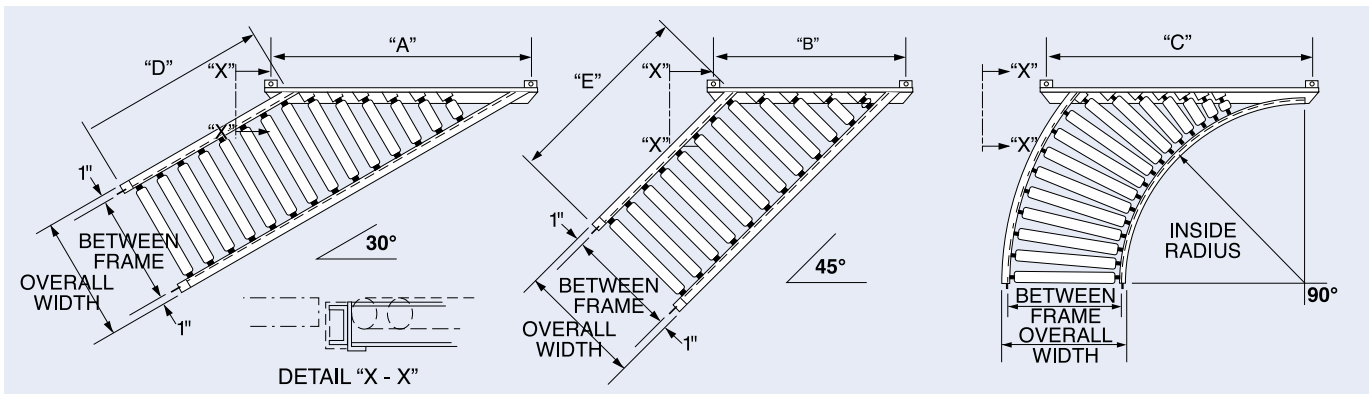

SPECIFICATIONS

Widths - 12", 15", 18" and 24"

Spurs - 30°, 45° and 90°

Couplings - Bar and hooks on one end

Right and left hand units

Bolt in cross members

Rollers - 1 3/8" diameter x 18 gauge galvanized rollers

Overall Frame Width	Model No.	30° SPUR				Model No.	45° SPUR				Model No.	90° SPUR	
		"A"	"D" Weights (lbs.)				"B"	"E" Weights (lbs.)				"C"	Weights (lbs.)
			2'	3'	5'			2'	3'	5'			
12"	138SRS-12-30	30"	35	43	64	138SRS-12-45	21"	31	39	60	138SRS-12-90	30"	29
15"	138SRS-15-30	39"	42	54	79	138SRS-15-45	30"	38	50	75	138SRS-15-90	39"	36
18"	138SRS-18-30	39"	48	62	91	138SRS-18-45	30"	44	58	87	138SRS-18-90	39"	42
24"	138SRS-24-30	51"	59	77	113	138SRS-24-45	39"	55	73	109	138SRS-24-90	51"	53

NOTE: Same per foot capacities as straight sections shown on page 72.

MODEL "190SRS, 190HSRS, and 20SRS" Gravity Roller Spur Conveyor

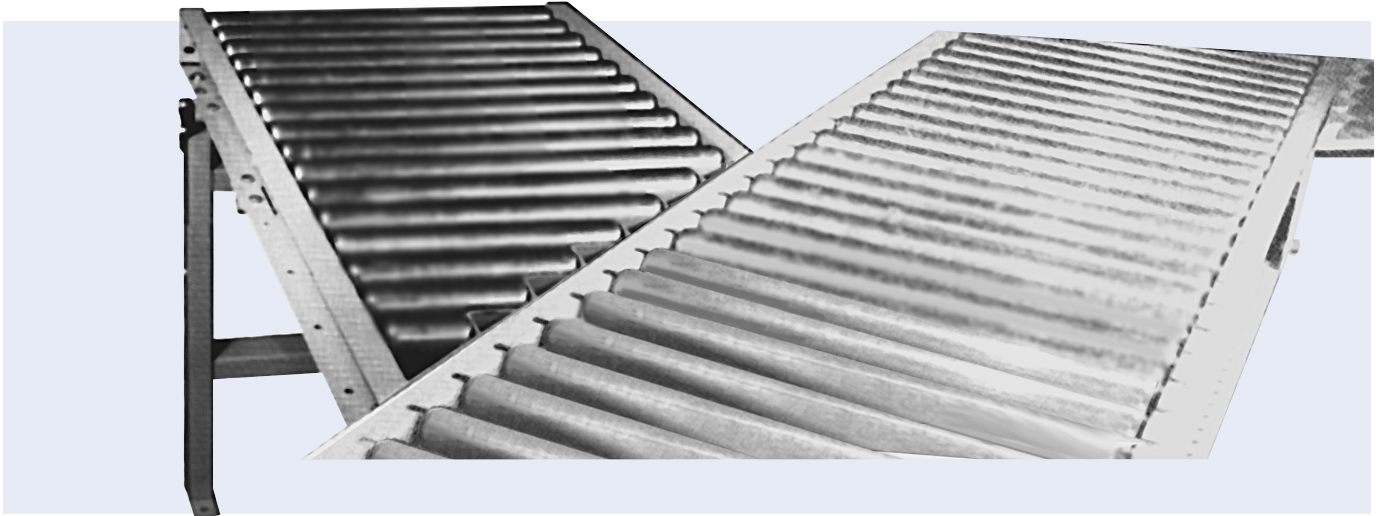

SPECIFICATIONS

Spurs - 30°, 45° and 90° models available

Right or left hand units

Couplings - Butt couplings one end

12" Width

Set high or low - set high is standard

Rollers - 1.9" diameter x 16 gauge unplated or galvanized steel; 2" diameter x 12 gauge unplated

NOTE: Same per foot capacities as straight sections shown on pages 76 and 77.

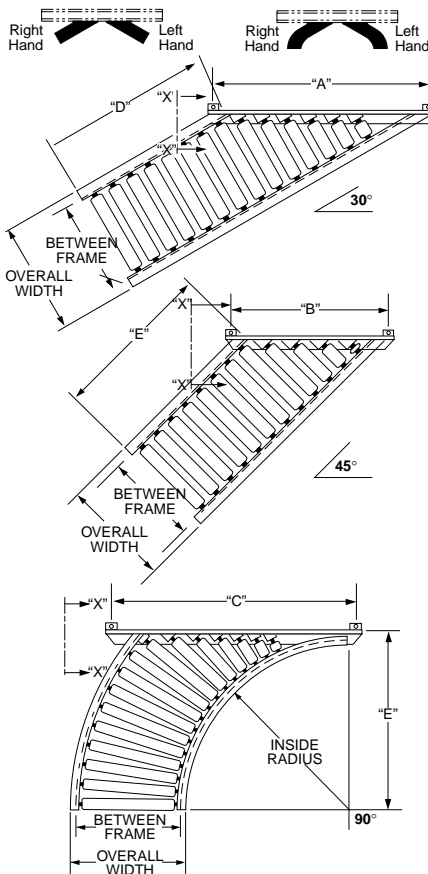

Between Rail Width	Nominal Roller Length	30° SPUR:				Weights (lbs.)					
		Model No.			"A"	"D"			"D"		
		1.9" Roller	1.9" Roller	2" Roller		1.9" Roller			2" Roller		
13"	12"	190SRS-13-30	190HSRS-13-30	20SRS-13-30	42"	56	73	107	68	89	131
15"	14"	190SRS-15-30	190HSRS-15-30	20SRS-15-30	42"	59	77	113	74	97	143
17"	16"	190SRS-17-30	190HSRS-17-30	20SRS-17-30	42"	62	81	119	77	101	149
19"	18"	190SRS-19-30	190HSRS-19-30	20SRS-19-30	54"	65	85	125	83	109	161
21"	20"	190SRS-21-30	190HSRS-21-30	20SRS-21-30	54"	71	93	137	89	117	173
23"	22"	190SRS-23-30	190HSRS-23-30	20SRS-23-30	54"	74	97	143	95	125	185
25"	24"	190SRS-25-30	190HSRS-25-30	20SRS-25-30	66"	77	101	149	101	133	197
27"	26"	190SRS-27-30	190HSRS-27-30	20SRS-27-30	66"	80	105	155	107	141	209
31"	30"	190SRS-31-30	190HSRS-31-30	20SRS-31-30	78"	89	117	173	119	157	223
33"	32"	190SRS-33-30	190HSRS-33-30	20SRS-33-30	78"	92	121	179	131	173	257
37"	36"	190SRS-37-30	190HSRS-37-30	20SRS-37-30	87"	95	125	185	134	177	263
39"	38"	190SRS-39-30	190HSRS-39-30	20SRS-39-30	87"	104	137	203	139	180	275
45° SPUR:						"B"					
13"	12"	190SRS-13-45	190HSRS-13-45	20SRS-13-45	33"	51	67	100	63	83	124
15"	14"	190SRS-15-45	190HSRS-15-45	20SRS-15-45	33"	54	71	112	72	95	142
17"	16"	190SRS-17-45	190HSRS-17-45	20SRS-17-45	33"	58	75	112	72	95	142
19"	18"	190SRS-19-45	190HSRS-19-45	20SRS-19-45	42"	60	79	119	78	103	154
21"	20"	190SRS-21-45	190HSRS-21-45	20SRS-21-45	42"	66	88	130	84	111	166
23"	22"	190SRS-23-45	190HSRS-23-45	20SRS-23-45	42"	69	91	136	90	119	179
25"	24"	190SRS-25-45	190HSRS-25-45	20SRS-25-45	48"	72	95	142	96	127	190
27"	26"	190SRS-27-45	190HSRS-27-45	20SRS-27-45	48"	75	99	148	102	135	202
31"	30"	190SRS-31-45	190HSRS-31-45	20SRS-31-45	54"	84	111	166	114	151	216
33"	32"	190SRS-33-45	190HSRS-33-45	20SRS-33-45	54"	84	115	172	126	166	250
37"	36"	190SRS-37-45	190HSRS-37-45	20SRS-37-45	66"	90	119	178	129	171	256
39"	38"	190SRS-39-45	190HSRS-39-45	20SRS-39-45	66"	99	131	196	134	174	269
90° SPUR:											
S R I O N L G L E R	Between Rail Width	Nominal Roller Length	Model No.			"C"	"E"	Inside Radius	Weights (lbs.)		
			1.9" Roller	1.9" Roller	2" Roller						
	13"	12"	190SRS-13-90	190HSRS-13-90	20SRS-13-90	42"		92			
	15"	14"	190SRS-15-90	190HSRS-15-90	20SRS-15-90	42"		100			
	17"	16"	190SRS-17-90	190HSRS-17-90	20SRS-17-90	48"		109			
	19"	18"	190SRS-19-90	190HSRS-19-90	20SRS-19-90	48"	33"	117			
	21"	20"	190SRS-21-90	190HSRS-21-90	20SRS-21-90	48"		126			
D R O O L B L E R	23"	22"	190SRS-23-90	190HSRS-23-90	20SRS-23-90	54"		156			
	25"	24"	190SRS-25-90	190HSRS-25-90	20SRS-25-90	54"		164			
	27"	26"	190SRS-27-90	190HSRS-27-90	20SRS-27-90	54"		172			
	31**	30"	190SRS-31-90	190HSRS-31-90	20SRS-31-90	66"		206			
	33**	32"	190SRS-33-90	190HSRS-33-90	20SRS-33-90	78"	48 1/2"	215			
	37**	36"	190SRS-37-90	190HSRS-37-90	20SRS-37-90	78"	48"	233			
	39**	38"	190SRS-39-90	190HSRS-39-90	20SRS-39-90	78"		242			

*4'0" inside radius. All others 2'8 1/2" inside radius.

MODEL "199SR & 199SRC"

Gravity Roller Conveyor

STANDARD SPECIFICATIONS

Frames - 3 1/2" deep x 1 1/2" x 10 gauge painted steel; painted bolt-in cross members; rollers set 1/4" high.

Rollers - 1.9" diameter x 9 gauge steel tubing. 2 1/2" to 1 1/16" tapered rollers available for curves.

Bearings - Labyrinth sealed and grease packed.

Axles - 7/16" hex shaft, spring-loaded.

Couplings - Butt type, for bolting sections together.

Widths - From 13" between frames (B/F) and wider in two inch increments up to 27" between frames. Also 31", 33", 37" and 39" between frames.

Lengths - 10' and 5' straight sections.

Curve Degree - 45° and 90° with 2'8 1/2" inside radius for widths up to 27" between frames. 4'0" inside radius for 31", 33", 37", and 39" between frames.

Capacity - 300 pounds per roller with 1,350 pounds maximum distributed live load over 10' length; 3,150 pounds maximum distributed live load over 5' length.

CURVED SECTIONS - WEIGHTS

TAPERED ROLLER CURVE

	Nominal Roller Length (Inches)	Width Between Frames (Inches)	Model No.	90° Weight (lbs.)	45° Weight (lbs.)
20 Rollers Per Curve	12	13	199SRC-13-90T	94	52
	14	15	199SRC-15-90T	126	68
	16	17	199SRC-17-90T	137	74
	18	19	199SRC-19-90T	152	81
	20	21	199SRC-21-90T	167	89
	22	23	199SRC-23-90T	178	94
32 Rollers Per Curve	24	25	199SRC-25-90T	204	107
	26	27	199SRC-27-90T	230	120
	30*	31	199SRC-31-90T	338	174
	32*	33	199SRC-33-90T	349	180
36*	37	199SRC-37-90T	371	191	
	38*	39	199SRC-39-90T	410	210

STRAIGHT ROLLER CURVE

Single Rollers 22 Per 90° Curve	12	13	199SRC-13-90S	97	50
	14	15	199SRC-15-90S	105	53
	16	17	199SRC-17-90S	114	58
	18	19	199SRC-19-90S	122	63
Double Rollers 42 Per 90° Curve	20	21	199SRC-21-90S	131	67
	22	23	199SRC-23-90D	161	82
	24	25	199SRC-25-90D	169	85
	26	27	199SRC-27-90D	177	89
	30*	31	199SRC-31-90D	211	108
	32*	33	199SRC-33-90D	220	112
	36*	37	199SRC-37-90D	238	120
	38*	39	199SRC-39-90D	247	124

*4'0" inside radius. All others 2'8 1/2" inside radius.

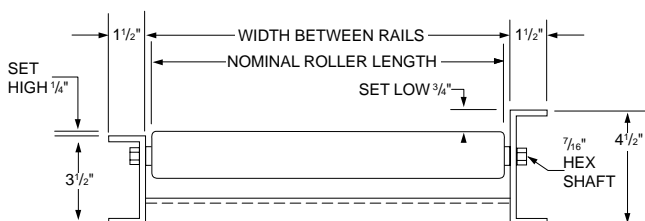

STRAIGHT SECTIONS - WEIGHTS

Nominal Roller Length	Width Between Frames	Model No.	Roller Centers (Inches)	10' Weight (lbs.)	5' Weight (lbs.)
12"	13"	199SR-13-3	3	233	119
		199SR-13-4 1/2	4 1/2	180	92
		199SR-13-6	6	152	78
		199SR-13-9	9	125	65
		199SR-13-12	12	110	57
14"	15"	199SR-15-3	3	255	130
		199SR-15-4 1/2	4 1/2	194	113
		199SR-15-6	6	163	84
		199SR-15-9	9	132	69
		199SR-15-12	12	116	60
16"	17"	199SR-17-3	3	276	141
		199SR-17-4 1/2	4 1/2	208	107
		199SR-17-6	6	173	89
		199SR-17-9	9	140	73
		199SR-17-12	12	121	62
18"	19"	199SR-19-3	3	299	152
		199SR-19-4 1/2	4 1/2	223	114
		199SR-19-6	6	185	95
		199SR-19-9	9	148	78
		199SR-19-12	12	127	66
20"	21"	199SR-21-3	3	322	164
		199SR-21-4 1/2	4 1/2	238	121
		199SR-21-6	6	196	100
		199SR-21-9	9	155	73
		199SR-21-12	12	132	68
22"	23"	199SR-23-3	3	344	175
		199SR-23-4 1/2	4 1/2	253	128
		199SR-23-6	6	208	106
		199SR-23-9	9	162	85
		199SR-23-12	12	138	71
24"	25"	199SR-25-3	3	366	186
		199SR-25-4 1/2	4 1/2	267	136
		199SR-25-6	6	219	111
		199SR-25-9	9	170	89
26"	27"	199SR-25-12	12	143	74
		199SR-27-3	3	389	196
		199SR-27-4 1/2	4 1/2	282	143
		199SR-27-6	6	230	117
30"	31"	199SR-27-9	9	178	103
		199SR-27-12	12	149	77
		199SR-31-3	3	434	219
		199SR-31-4 1/2	4 1/2	312	157
32"	33"	199SR-31-6	6	252	128
		199SR-31-9	9	192	100
		199SR-31-12	12	101	82
		199SR-33-3	3	456	230
36"	37"	199SR-33-4 1/2	4 1/2	326	166
		199SR-33-6	6	263	133
		199SR-33-9	9	201	105
		199SR-33-12	12	166	86
38"	39"	199SR-37-3	3	501	252
		199SR-37-4 1/2	4 1/2	356	180
		199SR-37-6	6	286	145
		199SR-37-9	9	215	112
39"	39"	199SR-37-12	12	177	91
		199SR-39-3	3	523	263
		199SR-39-4 1/2	4 1/2	371	187
		199SR-39-6	6	297	151
39"	39"	199SR-39-9	9	222	116
		199SR-39-12	12	183	93

MODEL "254SR & 254SRC"

Gravity Roller Conveyor



STANDARD SPECIFICATIONS

Frames - 3 1/2" deep x 1 1/2" x 10 gauge painted steel with bolted cross members. Also available in 4" @ 5.4 pound structural channel frame, optional. Rollers set 1/4" high.

Rollers - 2 1/2" diameter x 14 gauge steel tubing with swaged ends to provide firm bearing seat. 2 1/2" to 1 1/16" tapered rollers available for curves.

Bearings - Labyrinth sealed and grease packed, replaceable.

Axles - 7/16" hex shaft, spring-loaded.

Couplings - Butt type, for bolting sections together.

Widths - From 13" between frames (B/F) and wider in two inch increments up to 27" between frames. Also 31", 33", 37", 39", 45", 51" and 55" between frames.

Lengths - 10' and 5' straight sections.

Curve Degree - 45° and 90° with 2'8 1/2" inside radius for widths up to 27" between frames. 4'0" inside radius for 31", 33", 37", and 39" between frames.

Capacity - 350 pounds per roller on narrow sizes, with 1,350 pounds maximum live load on 10' sections; 3,300 pounds maximum live load on 5' section.

CURVED SECTIONS - WEIGHTS

	Nominal Roller Length (Inches)	Width Between Frames (Inches)	Model No.	90° Weight (lbs.)	45° Weight (lbs.)
Single Rollers	12	13	254SRC-13-90S	119	61
	14	15	254SRC-15-90S	131	68
	18 Per	17	254SRC-17-90S	144	73
	90°	18	254SRC-19-90S	155	80
	Curve	20	254SRC-21-90S	166	84
Double Rollers	22	23	254SRC-23-90D	199	101
	24	25	254SRC-25-90D	211	106
	26	27	254SRC-27-90D	223	112
	37 Per	30*	254SRC-31-90D	262	134
	90°	32*	254SRC-33-90D	275	140
	Curve	36*	254SRC-37-90D	301	152
20T Rollers	12	13	254SRC-13-90T	104	58
	14	15	254SRC-15-90T	115	63
	16	17	254SRC-17-90T	126	68
	18	19	254SRC-19-90T	139	75
	Per	20	254SRC-21-90T	171	91
Curve	22	23	254SRC-23-90T	182	96
	24	25	254SRC-25-90T	208	109
	26	27	254SRC-27-90T	210	110
	32T Rollers	30*	31	254SRC-31-90T	348
32*		33	254SRC-33-90T	359	185
36*		37	254SRC-37-90T	381	197
Curve		38*	254SRC-39-90T	420	215

*4'0" inside radius. All others 2'8 1/2" inside radius.

STRAIGHT SECTIONS - WEIGHTS

Nominal Roller Length	Width Between Frames	Model No.	Roller Centers (Inches)	10' Weight (lbs.)	5' Weight (lbs.)
12"	13"	254SR-13-3	3	230	128
		254SR-13-4 1/2	4 1/2	178	98
		254SR-13-6	6	134	83
		254SR-13-9	9	125	69
		254SR-13-12	12	110	59
14"	15"	254SR-15-3	3	250	137
		254SR-15-4 1/2	4 1/2	190	104
		254SR-15-6	6	160	87
		254SR-15-9	9	131	72
		254SR-15-12	12	114	62
16"	17"	254SR-17-3	3	268	146
		254SR-17-4 1/2	4 1/2	203	110
		254SR-17-6	6	169	92
		254SR-17-9	9	137	78
		254SR-17-12	12	119	64
18"	19"	254SR-19-3	3	287	156
		254SR-19-4 1/2	4 1/2	215	117
		254SR-19-6	6	178	97
		254SR-19-9	9	145	79
		254SR-19-12	12	124	67
20"	21"	254SR-21-3	3	307	166
		254SR-21-4 1/2	4 1/2	228	123
		254SR-21-6	6	178	101
		254SR-21-9	9	151	82
		254SR-21-12	12	128	69
22"	23"	254SR-23-3	3	325	175
		254SR-23-4 1/2	4 1/2	241	129
		254SR-23-6	6	198	106
		254SR-23-9	9	157	85
		254SR-23-12	12	133	72
24"	25"	254SR-25-3	3	344	184
		254SR-25-4 1/2	4 1/2	253	135
		254SR-25-6	6	208	111
		254SR-25-9	9	163	89
		254SR-25-12	12	138	73
26"	27"	254SR-27-3	3	364	190
		254SR-27-4 1/2	4 1/2	265	141
		254SR-27-6	6	217	115
		254SR-27-9	9	170	92
		254SR-27-12	12	142	76
30"	31"	254SR-31-3	3	402	213
		254SR-31-4 1/2	4 1/2	291	153
		254SR-31-6	6	233	125
		254SR-31-9	9	182	92
		254SR-31-12	12	153	81
32"	33"	254SR-33-3	3	421	223
		254SR-33-4 1/2	4 1/2	303	161
		254SR-33-6	6	245	129
		254SR-33-9	9	223	102
		254SR-33-12	12	157	84
36"	37"	254SR-37-3	3	459	241
		254SR-37-4 1/2	4 1/2	329	173
		254SR-37-6	6	264	140
		254SR-37-9	9	202	108
		254SR-37-12	12	167	88
38"	39"	254SR-39-3	3	477	251
		254SR-39-4 1/2	4 1/2	341	179
		254SR-39-6	6	274	143
		254SR-39-9	9	208	112
		254SR-39-12	12	171	90
44"	45"	254SR-45-3	3	534	278
		254SR-45-4 1/2	4 1/2	380	197
		254SR-45-6	6	303	160
		254SR-45-9	9	226	121
		254SR-45-12	12	186	96
50"	51"	254SR-51-3	3	591	305
		254SR-51-4 1/2	4 1/2	419	215
		254SR-51-6	6	331	176
		254SR-51-9	9	244	130
		254SR-51-12	12	201	102
54"	55"	254SR-55-3	3	629	323
		254SR-55-4 1/2	4 1/2	445	227
		254SR-55-6	6	350	187
		254SR-55-9	9	256	136
		254SR-55-12	12	211	106

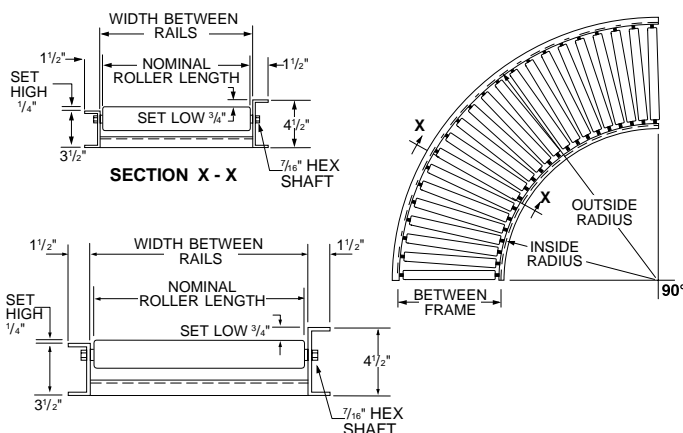

MODEL "251SR & 251SRC" Gravity Roller Conveyor

STANDARD SPECIFICATIONS

Frames - 4" x 4 gauge steel channel with bolted cross members, painted. Rollers set 1/4" high.

Rollers - 2 1/2" x 11 gauge steel tubing with straight press bearings.

Bearings - Labyrinth sealed and grease packed.

Axles - 1 1/16" hex shaft, spring-loaded.

Couplings - Splice plates, for bolting sections together.

Widths - 13" between frames (B/F) and wider in two inch increments up to 27" between frames. Also 31", 33", 37", 39", 45", 51", 55" and 59" between frames.

Lengths - 10' and 5' straight sections.

Curve Degree - 45° and 90° with 2'8 1/2" inside radius for widths up to 27" between frames. 4'0" inside radius for 31", 33", 37", and 39" between frames. Tapered roller curve available.

Capacity - 750 pounds per roller with 3,750 pounds maximum distributed live load over 10 feet for 12" nominal roller length, to 3,500 pounds on widest sizes; 8,000 pounds to 7,750 pounds maximum distributed live load over 5' lengths. Curve sections same as 10'. All capacities based on 3" centers.

CURVED SECTIONS - WEIGHTS

	Nominal Roller Length (Inches)	Width Between Frames (Inches)	Model No. (For 90°)	90° Weight (lbs.)	45° Weight (lbs.)
Single Roller	12	13	251SRC-13-90S	165	84
16 Per 90° Curve	14	15	251SRC-15-90S	180	91
	16	17	251SRC-17-90S	195	99
	18	19	251SRC-19-90S	210	106
	22	23	251SRC-23-90S	240	121
	26	27	251SRC-27-90S	270	136
Double Rollers	30*	31	251SRC-31-90D	400	216
37 Per 90° Curve	32*	33	251SRC-33-90D	418	236
	36*	37	251SRC-37-90D	453	245
	38*	39	251SRC-39-90D	471	255

*4'0" inside radius. All others 2'8 1/2" inside radius.

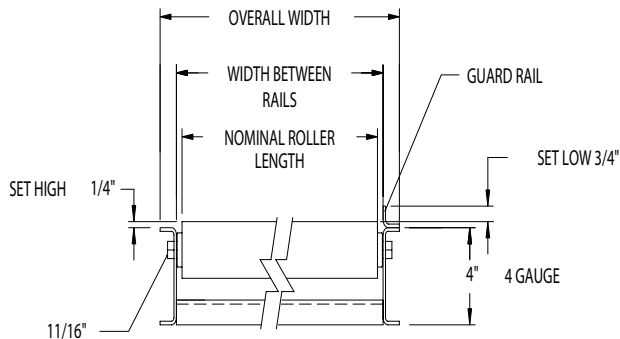

STRAIGHT SECTIONS - WEIGHTS

Nominal Roller Length	Width Between Frames	Model No.	Roller Centers (Inches)	10' Weight (lbs.)	5' Weight (lbs.)
12"	13"	251SR-13-3	3	364	185
		251SR-13-4	4	303	155
		251SR-13-6	6	242	125
		251SR-13-9	9	212	113
		251SR-13-12	12	182	95
14"	15"	251SR-15-3	3	395	202
		251SR-15-4	4	327	168
		251SR-15-6	6	259	134
		251SR-15-9	9	225	120
		251SR-15-12	12	191	100
16"	17"	251SR-17-3	3	427	218
		251SR-17-4	4	351	180
		251SR-17-6	6	276	142
		251SR-17-9	9	238	127
		251SR-17-12	12	200	104
18"	19"	251SR-19-3	3	458	234
		251SR-19-4	4	375	192
		251SR-19-6	6	292	151
		251SR-19-9	9	251	134
		251SR-19-12	12	209	110
22"	23"	251SR-23-3	3	521	266
		251SR-23-4	4	423	217
		251SR-23-6	6	325	168
		251SR-23-9	9	276	149
		251SR-23-12	12	227	120
26"	27"	251SR-27-3	3	583	289
		251SR-27-4	4	471	242
		251SR-27-6	6	358	186
		251SR-27-9	9	302	163
		251SR-27-12	12	246	129
30"	31"	251SR-31-3	3	646	331
		251SR-31-4	4	519	267
		251SR-31-6	6	391	203
		251SR-31-9	9	328	178
		251SR-31-12	12	264	139
32"	33"	251SR-33-3	3	679	347
		251SR-33-4	4	544	280
		251SR-33-6	6	409	213
		251SR-33-9	9	341	185
		251SR-33-12	12	273	145
36"	37"	251SR-37-3	3	740	379
		251SR-37-4	4	590	304
		251SR-37-6	6	441	229
		251SR-37-9	9	366	199
		251SR-37-12	12	291	154
38"	39"	251SR-39-3	3	771	395
		251SR-39-4	4	614	316
		251SR-39-6	6	457	238
		251SR-39-9	9	379	207
		251SR-39-12	12	300	159
44"	45"	251SR-45-3	3	863	443
		251SR-45-4	4	694	352
		251SR-45-6	6	473	291
		251SR-45-9	9	417	229
		251SR-45-12	12	327	173
50"	51"	251SR-51-3	3	955	491
		251SR-51-4	4	754	388
		251SR-51-6	6	489	344
		251SR-51-9	9	455	251
		251SR-51-12	12	354	187
54"	55"	251SR-55-3	3	1016	523
		251SR-55-4	4	800	412
		251SR-55-6	6	521	360
		251SR-55-9	9	480	265
		251SR-55-12	12	372	196
58"	59"	251SR-59-3	3	1077	555
		251SR-59-4	4	846	436
		251SR-59-6	6	553	376
		251SR-59-9	9	505	279
		251SR-59-12	12	309	205

MODEL "267SR & 267SRC"

Gravity Roller Conveyor



STANDARD SPECIFICATIONS

Frames - 4" deep x 4 gauge channel with bolted cross members, painted. Rollers set 1/4" high.

Rollers - 2 5/8" diameter x 7 gauge steel tubing with straight press bearings.

Bearings - Labyrinth sealed and grease packed.

Axles - 1 1/16" hex shaft, spring-loaded.

Couplings - Splice plates, for bolting sections together.

Widths - From 13" between frames (B/F) and wider in two inch increments up to 27" between frames. Also 31", 33", 37", 39", 45", 51", 55" and 59" between rails.

Lengths - 10' and 5' straight sections.

Curve Degree - 45° and 90° with 2'8 1/2" inside radius for widths up to 27" between frames. 4'0" inside radius for 31", 33", 37" and 39" between frames. Tapered roller curves available.

Capacity - 800 pounds per roller with 3,850 pounds maximum distributed live load over 10'; 8,100 pounds maximum distributed live load over 5' lengths. Curve sections same as 10'. All capacities based on 3" centers.

CURVED SECTIONS - WEIGHTS

	Nominal Roller Length (Inches)	Width Between Rails (Inches)	Model No. (For 90°)	90° Weight (lbs.)	45° Weight (lbs.)	
Single Rollers	12	13	267SRC-13-90S	190	96	
	14	15	267SRC-15-90S	209	106	
	16	17	267SRC-17-90S	229	116	
	18	19	267SRC-19-90S	248	125	
	16 Per 90° Curve	22	23	267SRC-23-90S	286	144
Double Rollers	30*	31	267SRC-31-90D	451	247	
	32*	33	267SRC-33-90D	493	268	
	37 Per 90° Curve	36*	267SRC-37-90D	538	292	
	90° Curve	38*	39	267SRC-39-90D	561	305

*4'0" inside radius. All others 2'8 1/2" inside radius.

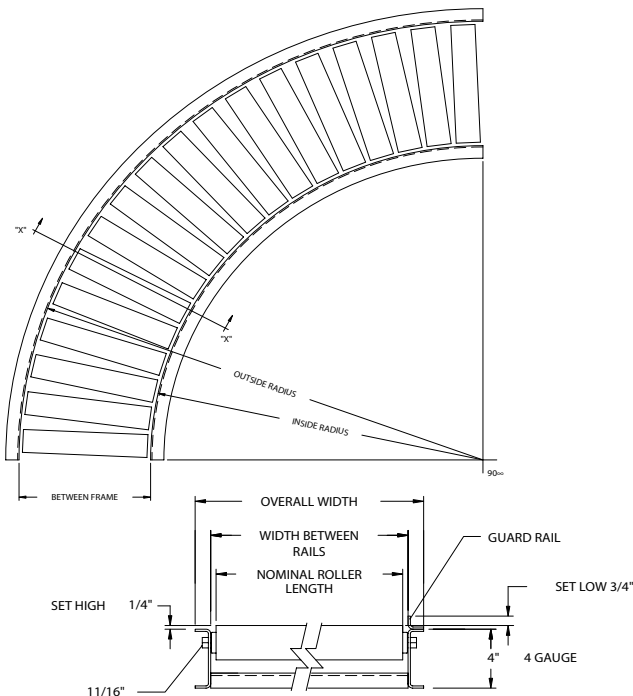

STRAIGHT SECTIONS - WEIGHTS

Nominal Roller Length	Width Between Frames	Model No.	Roller Centers (Inches)	10' Weight (lbs.)	5' Weight (lbs.)
12"	13"	267SR-13-3	3	427	217
		267SR-13-4	4	351	179
		267SR-13-6	6	274	141
		267SR-13-9	9	236	125
		267SR-13-12	12	198	102
14"	15"	267SR-15-3	3	469	239
		267SR-15-4	4	383	195
		267SR-15-6	6	296	152
		267SR-15-9	9	253	135
		267SR-15-12	12	209	109
16"	17"	267SR-17-3	3	511	260
		267SR-17-4	4	415	212
		267SR-17-6	6	318	163
		267SR-17-9	9	269	144
		267SR-17-12	12	221	115
18"	19"	267SR-19-3	3	553	282
		267SR-19-4	4	446	228
		267SR-19-6	6	340	175
		267SR-19-9	9	286	153
		267SR-19-12	12	233	121
22"	23"	267SR-23-3	3	637	324
		267SR-23-4	4	510	261
		267SR-23-6	6	383	198
		267SR-23-9	9	320	172
		267SR-23-12	12	256	134
26"	27"	267SR-27-3	3	721	367
		267SR-27-4	4	574	294
		267SR-27-6	6	427	220
		267SR-27-9	9	353	191
		267SR-27-12	12	280	147
30"	31"	267SR-31-3	3	805	410
		267SR-31-4	4	638	326
		267SR-31-6	6	471	243
		267SR-31-9	9	387	209
		267SR-31-12	12	304	159
32"	33"	267SR-33-3	3	847	431
		267SR-33-4	4	670	343
		267SR-33-6	6	492	254
		267SR-33-9	9	404	219
		267SR-33-12	12	315	166
36"	37"	267SR-37-3	3	931	474
		267SR-37-4	4	733	376
		267SR-37-6	6	536	277
		267SR-37-9	9	438	237
		267SR-37-12	12	339	178
38"	39"	267SR-39-3	3	973	496
		267SR-39-4	4	765	392
		267SR-39-6	6	558	288
		267SR-39-9	9	455	247
		267SR-39-12	12	351	185
44"	45"	267SR-45-3	3	1099	561
		267SR-45-4	4	860	441
		267SR-45-6	6	624	322
		267SR-45-9	9	506	275
		267SR-45-12	12	387	204
50"	51"	267SR-51-3	3	1225	626
		267SR-51-4	4	955	490
		267SR-51-6	6	690	356
		267SR-51-9	9	557	303
		267SR-51-12	12	423	223
54"	55"	267SR-55-3	3	1309	669
		267SR-55-4	4	1018	523
		267SR-55-6	6	734	379
		267SR-55-9	9	591	321
		267SR-55-12	12	447	235
58"	59"	267SR-59-3	3	1393	712
		267SR-59-4	4	1081	556
		267SR-59-6	6	778	402
		267SR-59-9	9	625	339
		267SR-59-12	12	471	247

MODELS "350SR & 350SRC"

Gravity Roller Conveyor

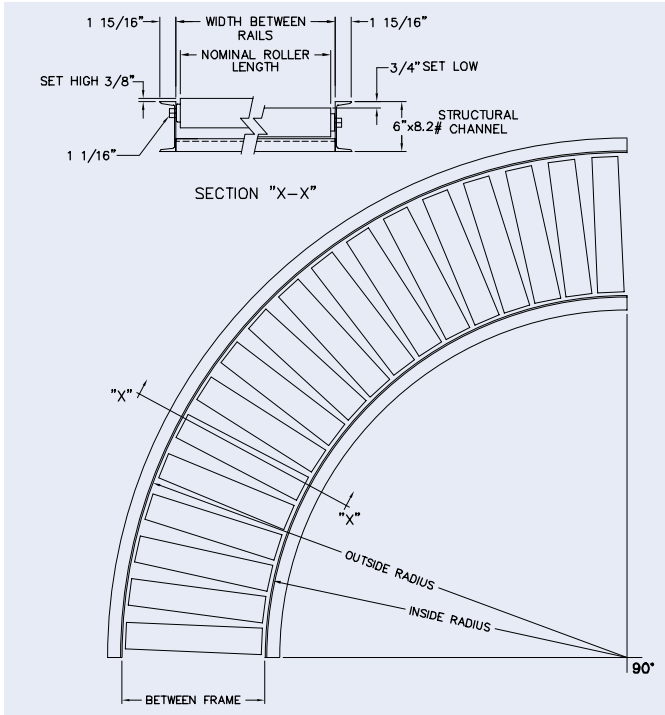

STANDARD SPECIFICATIONS

Frames - 6" x 8.2 pound structural steel channel with welded cross members painted. Rollers set 3/8" high.

Rollers - 3 1/2" diameter x .30 wall with machined ends for press fit bearings.

Bearings - Labyrinth sealed and grease packed.

Axles - 1 1/16" hex shaft, pinned.

Couplings - Butt type, for bolting frames together.

Widths - 7" between frames (B/F) and wider up to 51" between frames.

Length - 5' and 10' straight sections.

Capacity - 1300 pounds per roller, with 8400 pounds maximum distributed live load over 10 feet; 16,700 pounds maximum distributed live load over 5 feet lengths. All capacities are based on 4" centers.

Curve Degree - 45° and 90° with 4'0" inside radius only. Tapered rollers not available.

STRAIGHT SECTIONS - WEIGHTS

Nominal Roller Length	Width Between Frames	Model No.	Roller Centers (Inches)	10' Weight (lbs.)	5' Weight (lbs.)
6"	7"	350SR-7-4	4	468	236
		350SR-7-6	6	366	185
		350SR-7-8	8	315	160
		350SR-7-12	12	264	134
10"	11"	350SR-11-4	4	611	315
		350SR-11-6	6	464	234
		350SR-11-8	8	390	204
		350SR-11-12	12	317	168
14"	15"	350SR-15-4	4	755	387
		350SR-15-6	6	563	291
		350SR-15-8	8	466	242
		350SR-15-12	12	370	194
18"	19"	350SR-19-4	4	899	454
		350SR-19-6	6	661	332
		350SR-19-8	8	542	273
		350SR-19-12	12	423	214
22"	23"	350SR-23-4	4	1042	523
		350SR-23-6	6	759	383
		350SR-23-8	8	617	311
		350SR-23-12	12	476	240
26"	27"	350SR-27-4	4	1185	595
		350SR-27-6	6	857	431
		350SR-27-8	8	693	349
		350SR-27-12	12	529	267
30"	31"	350SR-31-4	4	1329	677
		350SR-31-6	6	955	480
		350SR-31-8	8	769	397
		350SR-31-12	12	582	293
34"	35"	350SR-35-4	4	1472	736
		350SR-35-6	6	1053	529
		350SR-35-8	8	844	424
		350SR-35-12	12	634	319
38"	39"	350SR-39-4	4	1615	810
		350SR-39-6	6	1151	578
		350SR-39-8	8	919	462
		350SR-39-12	12	687	346
42"	43"	350SR-43-4	4	1759	892
		350SR-43-6	6	1250	627
		350SR-43-8	8	994	500
		350SR-43-12	12	741	373
46"	47"	350SR-47-4	4	1903	954
		350SR-47-6	6	1348	676
		350SR-47-8	8	1071	538
		350SR-47-12	12	795	399
50"	51"	350SR-51-4	4	2045	1025
		350SR-51-6	6	1446	727
		350SR-51-8	8	1147	575
		350SR-51-12	12	846	425

CURVED SECTIONS - WEIGHTS

	Nominal Roller Length*	Width Between Frames	Model No. (for 90°)	90° Weight (lbs.)	45° Weight (lbs.)
18 Rollers per 90° Curve	6"	7"	350SRC-7-90S	328	165
	10"	11"	350SRC-11-90S	428	220
	14"	15"	350SRC-15-90S	529	270
	18"	19"	350SRC-19-90S	630	318
	22"	23"	350SRC-23-90S	729	366
	26"	27"	350SRC-27-90S	830	417
	30"	31"	350SRC-31-90S	930	474
	34"	35"	350SRC-35-90S	1030	515
	38"	39"	350SRC-39-90S	1131	567
	42"	43"	350SRC-43-90S	1231	625
	46"	47"	350SRC-47-90S	1332	668
	50"	51"	350SRC-51-90S	1432	718

*4'0" Inside Radius only.